

NORTH AMERICAN STANDARD OUT-OF-SERVICE CRITERIA

***April 1, 2016**

COMMERCIAL VEHICLE SAFETY ALLIANCE

Part I – North American Standard Driver Out-of-Service Criteria	Pages 1 - 12
Part II – North American Standard Vehicle Out-of-Service Criteria	Pages 13 - 62
Part III – North American Standard Hazardous Materials Out-of-Service Criteria	Pages 63 - 66
Part IV – North American Standard Administrative Out-of-Service Criteria	Pages 67 - 68
Appendix	Pages 69 - 94

**THIS DOCUMENT REPLACES AND SUPERSEDES ALL
PREVIOUS OUT-OF-SERVICE CRITERIA**



Promoting Uniformity in Commercial Motor Vehicle Safety & Enforcement

**Commercial Vehicle Safety Alliance
6303 Ivy Lane, Suite 310
Greenbelt, MD 20770
Phone: 301-830-6143 · www.cvsa.org**

This page intentionally left blank.

PART I – DRIVER

<u>DESCRIPTION</u>	<u>MANUAL PAGE</u>
1. DRIVER’S AGE	2
2. OPERATOR’S/CHAUFFEUR’S LICENSE OR PERMIT (NON CDL)	2
*3. COMMERCIAL DRIVER’S LICENSE (CDL)	2
License	2
*Commercial Learner’s Permit (CLP)	3
Endorsements and Restrictions	3
Classification	3
*4. DRIVER MEDICAL/PHYSICAL REQUIREMENTS	3
Skill Performance Evaluation Certificate	3
*Medical Certificate	3
5. SICKNESS	4
6. FATIGUE	4
7. DRUGS AND OTHER SUBSTANCES	4
8. INTOXICATING BEVERAGES	5
9. DRIVER’S RECORD OF DUTY STATUS – U.S.	5
Property-Carrying Vehicles	5
Passenger-Carrying Vehicles	6
Hours of Service Out-of-Service Order	7
Footnotes	7
10. DRIVER’S RECORD OF DUTY STATUS – Canada	9
Footnotes	10
11. DRIVER’S RECORD OF DUTY STATUS – Mexico	11

PART II – VEHICLE

<u>DESCRIPTION</u>	<u>MANUAL PAGE</u>
1. BRAKE SYSTEMS	
Defective Brakes (<i>20 Percent Rule</i>)	15
Absence of Effective Braking Action	15
Audible Air Leak at Air Chamber	16
Missing Brakes	16
Brake Adjustment Limits	16
Brake Adjustment Limit Charts	17
Drum Air Brakes	19
Air Disc Brakes	20
Hydraulic and Electric Brakes	20
Front Steering Axle(s) Brakes (<i>In Addition to the 20 Percent Rule</i>)	21
Inoperative or Missing Brake	21
Drum Air Brakes	21
Air Disc Brakes	22
Hydraulic Brakes	23
Spring Brake Chambers	23
Trailer Breakaway and Emergency Braking	23
Parking Brake	23
Brake Smoke/Fire	24
Brake Drums or Rotors (Disc)	24
Air Brake Hose/Tubing	24
Air Pressure Gauge	25
Low Air Pressure Warning Device	25
Air Loss Rate	25
Tractor Protection System	26
Air Reservoir (Tank)	26
Air Compressor	26
Hydraulic Brakes	26
Vacuum Brakes	27
Performance-Based Brake Test (PBBT)	27
*2. CARGO SECUREMENT	
General	27
Aggregate Working Load Limit	28
Commodity Specific Requirements	29
*Tiedown Defect Table	31
Chain Defects	31
Wire Rope Defects	32
Cordage (Fiber Rope) Defects	33
*Synthetic Webbing Defects	33
Steel Strapping Defects	35
Fitting/Attachment/Tensioning Device Defects	35
Anchor Point Defects	35

DESCRIPTION**MANUAL PAGE****3. COUPLING DEVICES**

Fifth Wheels	36
Lower Coupler Assembly	36
Upper Coupler Assembly (Including Kingpin)	38
Pintle Hooks	40
Drawbar Eye	40
Drawbar/Tongue	41
Safety Devices	41
Hitch Systems (Excluding Fifth Wheels and Pintle Hooks)	41
Saddle-Mounts (Method of Attachment)	42
Full Trailer (Double Ring, Ball-Bearing Turntable)	42

***4. DRIVELINE/DRIVESHAFT**

Yoke Ends (Including Slip Yoke, Yoke Shaft, Tube Yoke and End Fitting Yoke)	42
*Universal Joint	43
Center Bearing (Carrier Bearing)	43
Driveshaft Tube	44

5. EXHAUST SYSTEMS 44**6. FRAMES**

Frame Members	45
Tire and Wheel Clearance	45

***7. FUEL SYSTEMS**

Liquid Fuels	46
*Gaseous Fuels	46

***8. LIGHTING DEVICES (HEADLAMPS, TAIL LAMPS, STOP LAMPS, TURN SIGNALS AND LAMPS/FLAGS ON PROJECTING LOADS)**

When Required	47
*Anytime	47

***9. STEERING MECHANISMS**

Steering Wheel Lash (Free Play)	48
Steering Column	49
Front Axle Beam (Including Hub)	49
Steering Gear Box (Including Rack and Pinion)	49
Pitman Arm	50
*Power Steering	50
Ball and Socket Joints	50
Tie Rods and Drag Links	50

<u>DESCRIPTION</u>	<u>MANUAL PAGE</u>
Nuts	50
Steering System	51
C-Dolly	51
*10. SUSPENSIONS	
Axle Parts/Members	51
*Spring Assembly	51
Coil/Rubber Spring and Air Suspension	52
Composite Springs	53
Suspension Connecting Rod, Tracking Component Assembly or Sway Bar Components	54
Adjustable Axle(s)	55
*11. TIRES	
Front Steering Axle(s)	55
Other Than Front Steering Axle(s)	57
*Lodged Items Between Tires of a Dual Tire Set	58
12. VAN AND OPEN-TOP TRAILER BODIES	
Upper Rail	58
Lower Rail	58
Floor Crossmembers	59
Side Panels on Fiberglass Reinforced Plywood (FRP) Trailers	59
13. WHEELS, RIMS AND HUBS	
Lock or Side Ring	59
Rim Cracks	59
Disc Wheel Cracks	59
Bolt/Stud Holes (Disc Wheels)	60
Spoke Wheel Cracks	60
Tubeless Demountable Adapter Cracks	60
Wheel Fasteners	60
Welds	60
Hubs	60
14. WINDSHIELD WIPERS	61
15. BUSES, MOTOR COACHES, PASSENGER VANS OR OTHER PASSENGER CARRYING VEHICLES – EMERGENCY EXITS/ELECTRICAL CABLES AND SYSTEMS IN ENGINE AND BATTERY COMPARTMENTS/SEATING	
Emergency Exits	61
Electrical Cables and Systems in Engine and Battery Compartments	61
Loose and/or Temporary Seating	61

PART III – HAZARDOUS MATERIALS

<u>DESCRIPTION</u>	<u>MANUAL PAGE</u>
1. SHIPPING PAPERS	64
2. PLACARDING	64
3. BULK PACKAGES	64
4. TRANSPORT VEHICLE MARKINGS	65
5. POISON INHALATION HAZARD (PIH) MARKINGS	65
6. NON-BULK PACKAGING	65
7. LOADING AND SECUREMENT	65
8. FORBIDDEN ITEMS	66
9. RADIOACTIVE MATERIALS – RADIATION LEVELS	66
10. EMERGENCY RESPONSE ASSISTANCE PLAN (ERAP) (In Canada Only)	66

PART IV – ADMINISTRATIVE

<u>DESCRIPTION</u>	<u>MANUAL PAGE</u>
1. OPERATING AUTHORITY	68
2. MEXICO DOMICILED CARRIERS OPERATING IN THE U.S.	68
3. U.S. FEDERAL OUT-OF-SERVICE ORDERS	68

APPENDIX

<u>DESCRIPTION</u>	<u>MANUAL PAGE</u>
1. NORTH AMERICAN STANDARD INSPECTION LEVELS	70
2. QUALIFYING FOR CVSA DECALS	72
3. CRITICAL VEHICLE INSPECTION ITEMS	72
4. RAISED LIFT AXLE(S)	72
5. CVSA DECALS ON CARGO TANKS	73
6. VEHICLE INSPECTIONS	73
7. VEHICLE RE-INSPECTIONS	74
8. REQUIRED REPAIRS FOR OUT-OF-SERVICE NOTICES	74
9. LOCATION OF CVSA DECALS	75
10. APPLICATION OF CVSA DECALS	76
*11. INSPECTION BULLETINS	77
*12. OPERATIONAL POLICY 15 INSPECTION / REGULATORY GUIDANCE	79

Part I

**NORTH AMERICAN STANDARD DRIVER
OUT-OF-SERVICE CRITERIA**

POLICY STATEMENT

The purpose of this part is to identify violations that render the commercial motor vehicle operator unqualified to drive or out-of-service. The necessity for all enforcement personnel to implement and adhere to these standards is: (1) a matter of law; (2) perceived as necessary by the society we are charged with protecting, and (3) a professional obligation if substantial enhancement in the safety of commercial motor vehicle operators is to be achieved.

Except where state, provincial, territorial, or federal laws preclude enforcement of a named item, motor carrier safety enforcement personnel and their jurisdictions shall comply with these out-of-service violation standards.

OUT-OF-SERVICE VIOLATION: Violations under this category preclude further operation of a commercial motor vehicle by its driver for a specified period of time or for some violations until a required condition is met. An example of the former standard is hours of service violations.

FMCSR code references in the *North American Standard Out-of-Service Criteria* are simply recommendations to help inspectors find an appropriate citation. Other violation codes may be more suitable for a specific condition.

1. **DRIVER'S AGE**

Is not at least 21 years of age. (391.11(b)(1), see exemptions 390.3(f) and 391.2)
Declare driver out-of-service.

2. **OPERATOR'S/CHAUFFEUR'S LICENSE OR PERMIT (NON-CDL)**

a. Vehicle 26,000 lbs. or less GVWR not designed to transport 16 or more passengers or placarded loads of hazardous materials.

- (1) Is not licensed for the type of vehicle being operated. (391.11(b)(5))
Declare driver out-of-service. (*Out-of-service action to be initiated only upon home jurisdiction license verification.*)
- (2) Operating a non-CDL required commercial motor vehicle with driving privileges revoked, suspended, cancelled, or otherwise disqualified. (391.15(a)) **Declare driver out-of-service.** (*Out-of-service action to be initiated if a driver's license is suspended in a jurisdiction for any safety-related or unknown reason.*)

b. Endorsements and Restrictions

Operating a commercial vehicle without proper endorsement or in violation of restrictions. (391.11(b)(5)) **Declare driver out-of-service.**

NOTE: Canadian operator's license endorsements are included in the class. Transporting dangerous goods requires a training certificate. **Declare driver out-of-service if not in possession.**

NOTE: Mexican drivers must have a Category E license to transport hazardous materials. All other endorsements are included in the class. **Declare driver out-of-service if not in possession.**

*3. **COMMERCIAL DRIVER'S LICENSE (CDL)**

a. License

- (1) Does not possess a valid CDL issued by his/her state or jurisdiction of domicile. (383.23(a)(2)) **Declare driver out-of-service.** (*Out-of-service action to be initiated only upon home jurisdiction license verification.*)
- (2) Operating a CDL required commercial motor vehicle with driving privileges revoked, suspended, cancelled, or otherwise disqualified. (383.51(a)) **Declare driver out-of-service.** (*Out-of-service action to be initiated if a driver's license is suspended in a jurisdiction for any safety-related or unknown reason.*)

NOTE: Canadian operators not possessing a valid Provincial or Territorial license of the correct class. **Declare driver out-of-service.**

NOTE: Mexican operators who do not possess a valid Licencia Federal. (Can be recognized by the medallion in the upper left hand corner containing the Mexican national symbol of an eagle with a serpent. The words Licencia Federal de Conductor and logo SCT are also on the front of the license.) **Declare driver out-of-service.**

*b. Commercial Learner's Permit (CLP)

- (1) Is not accompanied by the holder of a valid CDL. (383.25(a)(1)) **Declare driver out-of-service.**
- (2) Does not hold a valid automobile drivers license or have a valid operator's status allowed by licensing jurisdiction. (383.25(a)(2)) **Declare driver out-of-service.**
- (3) Operating a commercial motor vehicle transporting hazardous materials as defined in 383.5. (383.25(a)(6)) **Declare driver out-of-service.**
- * (4) Operating a commercial motor vehicle transporting passengers requiring the passenger (P) or school bus (S) endorsement(s). (383.25(a)(5)(i) or 383.25(a)(5)(ii) for school buses) **Declare driver out-of-service.**

c. Endorsements and Restrictions

Operating a commercial vehicle without proper endorsements or in violation of restrictions. (383.23(a)(2)) **Declare driver out-of-service.**

NOTE: Canadian operator's license endorsements are included in the class. Transporting dangerous goods requires a training certificate. **Declare driver out-of-service if not in possession.**

NOTE: Mexican drivers must have a Category E license to transport hazardous materials. All other endorsements are included in the class.

d. Classification

Does not possess proper class of license for vehicle being operated. (383.91(a)) **Declare driver out-of-service.**

*4. **DRIVER MEDICAL/PHYSICAL REQUIREMENTS**

a. Skill Performance Evaluation Certificate

No skill performance evaluation in possession, when required. (391.49(j)) **Declare driver out-of-service.**

*b. Medical Certificate

- (1) Operating a commercial vehicle without corrective lenses or hearing aid as indicated on the driver's medical certificate. (391.11(b)(4)) **Declare driver out-of-service.**

- (2) When an inspector has knowledge and/or evidence that a driver is/is not in possession of a valid medical certificate, and is not in possession of any and all required exemptions for the following conditions: vision, hearing, insulin-using diabetes, epilepsy or any other condition which is likely to cause loss of consciousness or any loss of ability to control a commercial motor vehicle. (391.41(a)(1)) **Declare driver out-of-service.**
- * (3) Operating a non-CDL required passenger-carrying vehicle without a valid medical certificate in possession or on file with the State driver licensing agency. (391.41(a)) **Declare driver out-of-service.**
Inspection Bulletin 2015-04 – Enforcement of Medical Examiner’s Certificate Integration with the Commercial Driver’s License
- * (4) Operating a property-carrying vehicle without a valid medical certificate in possession or on file with the State driver licensing agency. If the driver fails to produce a medical certificate or has an expired medical certificate and has a previous history of failing to produce a medical certificate, or having an expired medical certificate. (391.41(a)) **Declare driver out-of-service.**
- (5) Operating a commercial motor vehicle with a fraudulent medical certificate. (390.35) **Declare driver out-of-service.**

***NOTE:** Canadian operators possessing a valid Provincial or Territorial license of the proper class, other than Class 5 or G, includes a valid Medical Certificate. A Class 5 or G license shall be accompanied by other evidence of compliance with medical requirements (e.g., certificate, endorsement, etc.).

NOTE: Mexican operators possessing a valid Licencia Federal de Conductor of the proper class includes a valid Medical Certificate.

5. **SICKNESS**

When so impaired that the driver should not continue the trip. (392.3) **Declare driver out-of-service until no longer impaired.**

6. **FATIGUE**

When a driver operates a commercial motor vehicle while his/her ability or alertness is so impaired, or so likely to become impaired, through fatigue as to make it unsafe for him/her to begin or continue to operate the commercial motor vehicle. (392.3) **Declare driver out-of-service until no longer fatigued.**

7. **DRUGS AND OTHER SUBSTANCES; AS IDENTIFIED UNDER SECTION 392.4(a).**

a. **Shall not be in possession**

Is in possession. (392.4(a))

Declare driver out-of-service for twenty-four (24) consecutive hours.

- b. Shall not be under the influence

Is under the influence, with probable cause. (392.4(a))

Declare driver out-of-service for twenty-four (24) consecutive hours.

8. INTOXICATING BEVERAGES

Under the influence of intoxicating beverage, consumes an intoxicating beverage regardless of its alcohol content, or have any measured alcohol concentration or any detected presence of alcohol while on duty, or operating or in physical control of a motor vehicle. (Consumption - 392.5(a)(1) or Presence/Influence - 392.5(a)(2)) **Declare driver out-of-service for twenty-four (24) consecutive hours.**

Be on duty or operate a motor vehicle while the driver possesses an intoxicating beverage, regardless of its alcohol content. (Possession - 392.5(a)(3)) **Declare driver out-of-service for twenty-four (24) consecutive hours.**

Driver violating any roadside out-of-service order regarding intoxicating beverages. (392.5(c)(2)) **Declare driver out-of-service for twenty-four (24) consecutive hours.**

NOTE: The driver would not be declared out-of-service, if the driver has taken time off equivalent to the original out-of-service order.

9. DRIVER'S RECORD OF DUTY STATUS – U.S.

- a. Property-Carrying Vehicles (395.3)

- (1) 11 Hour Rule (See Footnotes 3, 4, 6, and 8)

Driving more than eleven (11) hours following ten (10) consecutive hours off duty. (395.3(a)(3)(i)) **Declare driver out-of-service until such time as eligibility to drive is re-established.**

- (2) 14 Hour Rule (See Footnotes 3, 4, 5, 6, and 8)

Driving beyond the fourteenth (14) hour after coming on duty following ten (10) consecutive hours off duty. (395.3(a)(2)) **Declare driver out-of-service until such time as eligibility to drive is re-established.**

- (3) 60/70 Hour Rule (See Footnotes 3, 4, and 7)

Driving after being on duty more than 60 hours in seven (7) consecutive days or 70 hours in eight (8) consecutive days. (60 Hour Rule - 395.3(b)(1) or 70 Hour Rule - 395.3(b)(2)) **Declare driver out-of-service until such time as eligibility to drive is re-established.**

- (4) No Record of Duty Status (Log Book)

No record of duty status in possession when one is required. (395.8(a)) **Declare driver out-of-service for ten (10) consecutive hours.**

(5) No Previous 7 Days (See Footnotes 2 and 10)

Failing to have in possession a record of duty status for the previous seven (7) consecutive days. (395.8(k)(2), see exception 395.13(b)(3))
Declare driver out-of-service for ten (10) consecutive hours.

(6) False Record of Duty Status (Log Book)

A required record of duty status that does not accurately reflect the driver's actual activities and duty status (including time and location of each duty status change and the time spent in each duty status) in an apparent attempt to conceal a violation of an hours of service limitation. (395.8(e)) **Declare driver out-of-service for ten (10) consecutive hours.**

b. Passenger-Carrying Vehicles (395.5)

(1) 10 Hour Rule (See Footnotes 3, 4, and 8)

Driving more than ten (10) hours following eight (8) consecutive hours off duty. (395.5(a)(1)) **Declare driver out-of-service until such time as eligibility to drive is re-established.**

(2) 15 Hour Rule (See Footnotes 3, 4, and 8)

Driving for any period after having been on duty fifteen (15) hours following eight (8) consecutive hours off duty. (395.5(a)(2)) **Declare driver out-of-service until such time as eligibility to drive is re-established.**

(3) 60/70 Hour Rule (See Footnotes 3 and 4)

Driving after being on duty more than 60 hours in seven (7) consecutive days or 70 hours in eight (8) consecutive days. (60 Hour Rule - 395.5(b)(1) or 70 Hour Rule - 395.5(b)(2)) **Declare driver out-of-service until such time as eligibility to drive is re-established.**

(4) No Record of Duty Status (Log Book)

No record of duty status in possession when one is required. (395.8(a))
Declare driver out-of-service for eight (8) consecutive hours.

(5) No Previous 7 Days (See Footnotes 2 and 10)

Failing to have in possession a record of duty status for the previous seven (7) consecutive days. (395.8(k)(2)), see exception 395.13(b)(3))
Declare driver out-of-service for eight (8) consecutive hours.

(6) False Record of Duty Status (Log Book)

A required record of duty status that does not accurately reflect the driver's actual activities and duty status (including time and location of each duty status change and the time spent in each duty status) in an apparent attempt to conceal a violation of an hours of service limitation. (395.8(e)) **Declare driver out-of-service for eight (8) consecutive hours.**

c. Hours of Service Out-of-Service Order (See Footnote 9)

Driver violating any roadside out-of-service order regarding hours of service. (395.13(d)(1)) **Declare driver out-of-service for ten (10) consecutive hours.**

Footnotes for driver's record of duty status – U.S.

1. Removed and reserved.
2. Exception (395.13(b)(3)). A driver failing only to have possession of a record of duty status current on the day of examination and the prior day, but has completed records of duty status up to that time (previous 6 days) will be given the opportunity to make the duty status record current.
3. Drivers must comply with the hours of service rules of the country (Canada, United States or Mexico) that the driver is operating (driving) in.
4. Drivers operating in the State of Alaska (395.1(h)).
 - a. Property-Carrying CMV-15 hours driving time and 20 hours on duty time following 10 hours off duty. 70 hours in 7 consecutive days, and 80 hours in 8 consecutive days.
 - b. Passenger-Carrying CMV-15 hours driving time and 20 hours on duty time following 8 hours off duty. 70 hours in 7 consecutive days, and 80 hours in 8 consecutive days.
5. Exception (395.1(o)). A property-carrying driver is allowed one (1) 16 hour on duty day within the current 7 or 8 consecutive day period provided the driver has returned to the driver's normal work reporting location and the carrier released the driver from duty at that location for the previous five duty tours the driver has worked.

NOTE: The driver *may* have more than one (1) 16 hour on duty day within the previous 7 or 8 day calendar period in circumstances when there is a valid 34 hour restart.
6. Exception (395.1(e)(2)). A *Short Haul Property Carrying Driver, not requiring a CDL, and within a 150 air-mile radius* is allowed two (2) 16 hour on duty days within any 7 consecutive day period provided the driver has returned to the driver's normal work reporting location at the end of each duty tour. The motor carrier that employs the driver must maintain and retain accurate and true time records for 6 months. See 395.1(e)(2)(i-ix) for all provisions of the exception.

NOTE: Drivers taking advantage of this exception *cannot* use the provisions of 395.1(e)(1) [100 air-mile radius], (g) [Sleeper Berths] and (o) [one 16-hour duty tour].

7. 34 Hour Restart (395.3(c)(1) or (2)). Any period of 7 or 8 consecutive days may end with the beginning of any off duty period of 34 or more consecutive hours.
8. Travel Time (395.1(j)(1)&(2)). When a driver at the direction of the motor carrier is traveling, but has no direct responsibility to the carrier, the time is counted as on-duty time *unless* the driver is afforded at least (for property carrying vehicles) 10, or, (for passenger carrying vehicles) 8 consecutive hours off duty when arriving at the destination. In this case the driver is off duty for the entire period.
9. The driver would not be declared out-of-service, if the driver has taken time off equivalent to the original out-of-service order.
10. A driver who utilizes an electronic device other than those described in 395.15 shall not be declared out-of-service if the driver has the ability to print and sign previously completed record of duty status that comply with 395.8 upon demand.

Inspection Bulletin 2012-05 – Automatic On-Board Recording Devices (AOBRDs)

10. **DRIVER'S RECORD OF DUTY STATUS – Canada**

a. Driver Impairment

Driver's faculties are impaired to the point where it is unsafe for the driver to drive, or driving would likely jeopardize safety. **Declare driver out-of-service for ten (10) consecutive hours.**

b. 13 Hour Rule (See Footnotes 1, 3, and 4)

(1) Driving more than thirteen (13) hours following eight consecutive hours off duty. **Declare driver out-of-service for eight (8) consecutive hours.**

(2) Driving more than thirteen (13) hours in a day. **Declare driver out-of-service for ten (10) consecutive hours.**

c. 14 Hour Rule (See Footnotes 1, 3, and 4)

(1) Driving for any period after having been on duty fourteen (14) hours following eight (8) consecutive hours off duty. **Declare driver out-of-service for eight (8) consecutive hours.**

(2) Driving for any period after having been on duty fourteen (14) hours in a day. **Declare driver out-of-service for ten (10) consecutive hours.**

d. 16 Hour Rule (See Footnotes 1 and 4)

Drive after sixteen (16) hours of elapsed time between mandatory periods of off duty time. **Declare driver out-of-service for eight (8) consecutive hours.**

e. 70/120 Hour Rules (See Footnotes 1, 3, 4, and 5)

Driving after being on duty more than 70 hours in seven (7) consecutive days or 120 hours in fourteen (14) consecutive days. **Declare driver out-of-service until such time as eligibility to drive is re-established.**

f. 10 Hour Off Duty Rule (See Footnote 1)

Driver fails to take ten (10) hours off duty in a day. **Declare driver out-of-service until such time as eligibility to drive is re-established.**

g. 24 Hours Off (See Footnote 1)

Driver fails to take twenty-four (24) hours off duty in the previous fourteen (14) days. **Declare driver out-of-service for twenty-four (24) consecutive hours.**

h. No Daily Log (See Footnote 2)

The driver is unable or refuses to produce a daily log for the current trip, a copy of the daily logs for the previous fourteen consecutive days, or any supporting

documents relevant to the current trip. **Declare driver out-of-service for seventy-two (72) consecutive hours.**

i. False Log (See Footnote 1)

A daily log that does not accurately reflect the driver's actual activities and duty status (including time and location of each duty status change and the time spent in each duty status) in an apparent attempt to conceal a violation of an hours of service limitation. **Declare driver out-of-service for seventy-two (72) consecutive hours.**

Footnotes for driver's record of duty status – Canada

1. Sleeper Berth Operations
 - a. Drivers involved in sleeper berth operations (sleeper teams) declared out-of-service for "Hours of Service" violations may be replaced by a co-driver, if the co-driver has hours available to drive.
 - b. A solo driver using a sleeper berth to obtain rest who exceeds the hours of service limitations shall be declared out-of-service until said driver has hours available to drive.
 2. A driver failing only to have possession of a daily log current on the day of examination and/or the prior day, but has completed required daily logs up to that time will be given the opportunity to make the daily log current.
 3. Drivers must comply with the hours of service rules of the country (Canada, United States or Mexico) that the driver is operating (driving) in.
 4. Drivers operating north of the 60th parallel may not drive after accumulating 15 hours driving time, 18 hours on-duty time, 20 hours of elapsed time between mandatory periods of off duty time, 80 hours in 7 consecutive days or 120 hours in 14 days.
 5. When applying the 120 hours in a 14 consecutive day period, drivers must take 24 consecutive hours off-duty prior to accumulating more than 70 hours on duty (prior to accumulating more than 80 hours on duty north of 60th parallel).
-

11. **DRIVER'S RECORD OF DUTY STATUS – Mexico**

a. Daytime Working Day (6:00-20:00)

Driving more than eight (8) hours in the daytime working day; it can also be increased up to three more hours during three non-consecutive days per week. **It is considered that the driver must not resume his/her work until the beginning of the following daytime working day. For each working day, the driver must have at least a half-hour break.**

b. Daytime Working Week (6:00-20:00)

Driving after being on duty more than 54 hours in the daytime working week during seven consecutive days, in which there were half-hour breaks during each working day. **It is considered that the driver must not resume his/her work until having at least 24 hours of rest.**

c. Night Working Day (20:00-6:00)

Driving more than seven (7) hours in the night working day; it can also be increased up to three more hours during three non-consecutive days per week. **It is considered that the driver must not resume his/her work until the beginning of the following night working day. For each working day, the driver must have at least a half-hour break.**

d. Night Working Week (20:00-6:00)

Driving after being on duty more than 48 hours in the night working week during seven consecutive days, in which there were half-hour breaks during each working day. **It is considered that the driver must not resume his/her work until having at least 24 hours of rest.**

e. Mixed Working Day (periods between the daytime and night working days; 3-1/2 hour maximum in the night working day)

Driving more than seven and a half (7-1/2) hours in the mixed working day; it can also be increased up to three more hours during three non-consecutive days per week. **It is considered that the driver must not resume his/her work until the beginning of the following mixed working day. For each working day, the driver must have at least a half-hour break.**

f. Mixed Working Week (periods between the daytime and night working days; 3-1/2 hour maximum per night working day)

Driving after being on duty more than 51 hours in the night working week during seven consecutive days, in which there were half-hour breaks during each working day. **It is considered that the driver must not resume his/her work until having at least 24 hours of rest.**

g. No Record of Duty Status (Log Book)

No record of duty status in possession when one is required. **It is considered that the driver must not resume his/her work until the beginning of the following working day.**

h. No Previous 7 Days

Failing to have in possession a record of duty status for the previous seven (7) consecutive days. **It is considered that the driver must not resume his/her work until having at least 24 hours of rest.**

i. False Record of Duty Status (Log Book)

A required record of duty status that does not accurately reflect the driver's actual activities and duty status (including time and location of each duty status change and the time spent in each duty status) in an apparent attempt to conceal a violation of an hours of service limitation. **It is considered that the driver must not resume his/her work until the beginning of the following working day or until having 24 hours of rest in the working week.**

Part II

NORTH AMERICAN STANDARD VEHICLE OUT-OF-SERVICE CRITERIA

POLICY STATEMENT

The purpose of this part is to identify Critical Vehicle Inspection Items and provide criteria for declaring vehicles out-of-service subsequent to a safety inspection.

Except where state, provincial, territorial, or federal laws preclude enforcement of a named item, motor carrier safety enforcement personnel and their jurisdictions shall comply with these out-of-service violation standards.

NOTE: Decal Qualification: Each vehicle (e.g., motorcoach, school bus, other bus, truck, truck tractor, semi-trailer, trailer, converter dollies, etc.) used singularly or in combination may qualify for a CVSA decal if it passes inspection, and a CVSA decal shall be applied. "Pass Inspection" means that during a North American Standard Level I or Level V Inspection no defects are found in the Critical Vehicle Inspection Items.

For the purpose of a CVSA decal issuance, if no violation is detected during a North American Standard Level I or Level V Inspection due to a hidden part, other than pushrod stroke measurements, of the listed Critical Vehicle Inspection Items, then a CVSA decal shall be applied. However, if more than 20 percent of pushrod travel, on exposed pushrods, cannot be measured, then a CVSA decal shall not be applied. If a brake measurement was not obtained due to a hidden component, then "NM" shall be documented for that wheel-end brake as well as being noted on the inspection report that it was not measured due to a hidden component. Brakes not measured will be considered compliant and still included in the 20 percent calculation. An inspector can still apply a CVSA decal even though his/her jurisdiction does not allow for the inspection of gaseous fuel systems.

The decal criteria applies only to the condition of the vehicle, not the driver. It is possible for a driver to be out-of-service and still have vehicle(s) qualify for a decal. If each vehicle, whether used singly or in a combination, passes inspection, a current CVSA decal shall be affixed and no other CVSA decals shall be visible.

OUT-OF-SERVICE: Authorized personnel shall declare "out-of-service" any motor vehicle which by reason of its mechanical condition or loading would be likely to cause an accident or breakdown. An "out-of-service vehicle" sticker shall be used to declare vehicles "out-of-service." No motor carrier shall require nor shall any person operate, or any inspector release any commercial motor vehicle declared "out-of-service" until all repairs required by the "out-of-service notice" have been satisfactorily completed to where a violation no longer exists.

When a vehicle is declared out-of-service for a condition resulting from an accumulation of violations, all violations that contributed to the specific out-of-service condition must be repaired (e.g., a vehicle, or vehicles in combination declared out-of-service for 20 percent defective brake violations must have all the 20 percent defective brake violations repaired prior to being released; or, a vehicle declared out-of-service for two tires at less than 1/32 inch (0.8 mm) tread depth must have both tire violations repaired prior to the vehicle being released, etc.). Once all of the contributing out-of-service violations have been repaired on any vehicle in a combination, that specific vehicle in the combination is no longer considered to be out-of-service.

An out-of-service condition cannot be corrected by creating a new violation (i.e., if a vehicle is declared out-of-service for three missing wheel fasteners on one wheel, wheel fasteners from other wheels cannot be removed to correct this out-of-service condition, etc.).

When vehicles in combination are declared out-of-service for 20 percent defective brake violations, any vehicle within the combination that does not contain a brake violation that contributed to the 20 percent defective brake out-of-service condition is allowed to proceed providing it does not contain any other out-of-service conditions.

No person shall remove the “out-of-service vehicle” sticker from any motor vehicle prior to completion of all repairs required by the “out-of-service notice.”

Violations, other than out-of-service conditions, detected during the inspection process will not preclude the completion of the current trip or dispatch. However, such violations must be corrected or repaired prior to re-dispatch.

A Critical Vehicle Inspection Item violation(s) (OOS or otherwise) noted during a CVSA Level I inspection that is successfully repaired on-site and re-inspected by the same inspector at the same inspection location will qualify for a CVSA decal as long as all previously noted Critical Vehicle Inspection Item violation(s) have been properly repaired. In such instances, only a re-inspection of the repaired violation(s) shall be done with decal(s) being applied to the vehicle(s) and properly noted upon the original inspection.

Any vehicle that is repaired off-site or inspected by a different inspector shall be required to have a complete inspection conducted in order to obtain a CVSA decal.

These criteria are neither suited nor intended to serve as vehicle maintenance or performance standards.

FMCSR code references in the *North American Standard Out-of-Service Criteria* are simply recommendations to help inspectors find an appropriate citation. Other violation codes may be more suitable for a specific condition.

1. **BRAKE SYSTEMS**

a. **Defective Brakes**

The number of defective brakes is equal to or greater than 20 percent of the service brakes on the vehicle or combination. A defective brake includes any brake that meets one of the following conditions. (396.3(a)(1))

NOTE: Steering axle brakes under “Front Steering Axle(s) Brakes”, are to be included in the 20 percent criterion.

Defective Brake Chart (below) shall be used in determining when a vehicle/combination is to be declared out-of-service.

Total Number of Brakes Required to be on a Vehicle Combination	Total Number of Defective Brakes Necessary to Declare the Vehicle or Combination Out-of-Service
4	1
6	2
8	2
10	2
12	3
14	3
16	4
18	4
20	4
22	5
**	

**** Vehicle Combination with More Than 22 Brakes – Total Number of Defective Brakes Necessary to Declare the Vehicle Combination Out-of-Service.**

Determine the number of defective brakes required by using 20 percent of the total number of brakes on the vehicle or combination (e.g., $24 \times 0.2 = 4.8$ brakes). Round all fractions up to the next whole number (e.g., 4.8 brakes = 5 required defective brakes).

- (1) Absence of effective braking action upon application of the service brakes (such as any brake lining/pad failing to move or contact braking surface upon application). (393.48(a))
Inspection Bulletin 2005-01 – Trailer Brake Controller (TBC) 2005 Ford SuperDuty Vehicles

- (2) Audible Air Leak at Air Chamber. (Example: ruptured diaphragm, loose chamber clamp, etc.) (396.3(a)(1))

NOTE: Refer to “Air Loss Rate”.

- (3) Missing brake on any axle required to have brakes. (393.42(a))
- (4) Brake Adjustment Limits. Bring reservoir pressure between 90 – 100 psi (620 – 690 kPa), turn engine off and then fully apply the brakes. All brake measurements shall be made in 1/8 inch (3.2 mm) increments.

- (a) One brake at 1/4 inch (6.4 mm) or more beyond the adjustment limit. (Example: Type 30 clamp type air chamber pushrod measured at 2-1/4 inches (57.2 mm) would be one defective brake.) (393.47(e))
- (b) A brake found at 1/8 inch (3.2 mm) beyond the brake adjustment limit shall be considered 0.5 (1/2) a defective brake for determining the number of defective brakes per the 20 percent defective brake criterion. (Example: Type 30 clamp type brake chamber pushrods measure – Two (2) at 2-1/8 inches (54.0 mm) equal 1 defective brake.) (393.47(e))

NOTE: When the vehicle, or combination of vehicles, is declared out-of-service for 20 percent brake violations, all brakes found beyond the brake adjustment limit must be repaired.

NOTE: When calculating/determining the number of defective brakes, round all fractions down to the next whole number (e.g., 4.5 brake violations = 4 defective brakes).

- (c) Any wedge brake where the combined brake lining movement of both top and bottom shoes exceeds 1/8 inch (3.2 mm). (393.47(f))

COMMERCIAL VEHICLE SAFETY ALLIANCE
NORTH AMERICAN STANDARD OUT-OF-SERVICE CRITERIA
REFERENCE CHARTS

Reference: "Defective Brakes" of Part II of the *North American Standard Out-of-Service Criteria*.

Brake Adjustment: Shall not exceed those specifications contained hereunder relating to "Brake Adjustment Limit". (Dimensions are in inches/millimeters.)

CLAMP TYPE BRAKE CHAMBER DATA

Type	Outside Diameter	Brake Adjustment Limit	Half Defect Limit	Full Defect Limit
6	4 1/2 (114 mm)	1 1/4 (31.8 mm)	1 3/8 (34.9 mm)	1 1/2 (38.1 mm)
9	5 1/4 (133 mm)	1 3/8 (34.9 mm)	1 1/2 (38.1 mm)	1 5/8 (41.3 mm)
12	5 11/16 (145 mm)	1 3/8 (34.9 mm)	1 1/2 (38.1 mm)	1 5/8 (41.3 mm)
16	6 3/8 (162 mm)	1 3/4 (44.5 mm)	1 7/8 (47.6 mm)	2 (50.8 mm)
20	6 25/32 (172 mm)	1 3/4 (44.5 mm)	1 7/8 (47.6 mm)	2 (50.8 mm)
24	7 7/32 (184 mm)	1 3/4 (44.5 mm)	1 7/8 (47.6 mm)	2 (50.8 mm)
30	8 3/32 (206 mm)	2 (50.8 mm)	2 1/8 (54.0 mm)	2 1/4 (57.2 mm)
36	9 (229 mm)	2 1/4 (57.2 mm)	2 3/8 (60.3 mm)	2 1/2 (63.5 mm)

NOTE: Service chambers with housings that are permanently crimped and sealed together are considered clamp type chambers even though they do not have a separate clamp band.

NOTE: A brake found at the adjustment limit is not a defect for the purposes of the 20 percent rule.

LONG STROKE' CLAMP TYPE BRAKE CHAMBER DATA

Type	Outside Diameter	Brake Adjustment Limit	Half Defect Limit	Full Defect Limit
12	5 11/16 (145 mm)	1 3/4 (44.5 mm)	1 7/8 (47.6 mm)	2 (50.8 mm)
16	6 3/8 (162 mm)	2 (50.8 mm)	2 1/8 (54.0 mm)	2 1/4 (57.2 mm)
20 (2 1/2" Rated Stroke)	6 25/32 (172 mm)	2 (50.8 mm)	2 1/8 (54.0 mm)	2 1/4 (57.2 mm)
20 (3" Rated Stroke)	6 25/32 (172 mm)	2 1/2 (63.5 mm)	2 5/8 (66.7 mm)	2 3/4 (69.9 mm)
24 (2 1/2" Rated Stroke)	7 7/32 (184 mm)	2 (50.8 mm)	2 1/8 (54.0 mm)	2 1/4 (57.2 mm)
24 (3" Rated Stroke)	7 7/32 (184 mm)	2 1/2 (63.5 mm)	2 5/8 (66.7 mm)	2 3/4 (69.9 mm)
30	8 3/32 (206 mm)	2 1/2 (63.5 mm)	2 5/8 (66.7 mm)	2 3/4 (69.9 mm)

NOTE: Rated stroke is indicated on a tag and is only used to identify chamber size.

NOTE: Service chambers with housings that are permanently crimped and sealed together are considered clamp type chambers even though they do not have a separate clamp band.

NOTE: A brake found at the adjustment limit is not a defect for the purposes of the 20 percent rule.

BOLT TYPE BRAKE CHAMBER DATA

Type	Outside Diameter	Brake Adjustment Limit	Half Defect Limit	Full Defect Limit
A	6 15/16 (176 mm)	1 3/8 (34.9 mm)	1 1/2 (38.1 mm)	1 5/8 (41.3 mm)
B	9 3/16 (234 mm)	1 3/4 (44.5 mm)	1 7/8 (47.6 mm)	2 (50.8 mm)
C	8 1/16 (205 mm)	1 3/4 (44.5 mm)	1 7/8 (47.6 mm)	2 (50.8 mm)
D	5 1/4 (133 mm)	1 1/4 (31.8 mm)	1 3/8 (34.9 mm)	1 1/2 (38.1 mm)
E	6 3/16 (157 mm)	1 3/8 (34.9 mm)	1 1/2 (38.1 mm)	1 5/8 (41.3 mm)
F	11 (279 mm)	2 1/4 (57.2 mm)	2 3/8 (60.3 mm)	2 1/2 (63.5 mm)
G	9 7/8 (251 mm)	2 (50.8 mm)	2 1/8 (54.0 mm)	2 1/4 (57.2 mm)

NOTE: A brake found at the adjustment limit is not a defect for the purposes of the 20 percent rule.

ROTOCHAMBER DATA

Type	Outside Diameter	Brake Adjustment Limit	Half Defect Limit	Full Defect Limit
9	4 9/32 (109 mm)	1 1/2 (38.1 mm)	1 5/8 (41.3 mm)	1 3/4 (44.5 mm)
12	4 13/16 (122 mm)	1 1/2 (38.1 mm)	1 5/8 (41.3 mm)	1 3/4 (44.5 mm)
16	5 13/32 (138 mm)	2 (50.8 mm)	2 1/8 (54.0 mm)	2 1/4 (57.2 mm)
20	5 15/16 (151 mm)	2 (50.8 mm)	2 1/8 (54.0 mm)	2 1/4 (57.2 mm)
24	6 13/32 (163 mm)	2 (50.8 mm)	2 1/8 (54.0 mm)	2 1/4 (57.2 mm)
30	7 1/16 (180 mm)	2 1/4 (57.2 mm)	2 3/8 (60.3 mm)	2 1/2 (63.5 mm)
36	7 5/8 (194 mm)	2 3/4 (69.9 mm)	2 7/8 (73.0 mm)	3 (76.2 mm)
50	8 7/8 (226 mm)	3 (76.2 mm)	3 1/8 (79.4 mm)	3 1/4 (82.6 mm)

NOTE: A brake found at the adjustment limit is not a defect for the purposes of the 20 percent rule.

DD-3 BRAKE CHAMBER DATA

Type	Outside Diameter	Brake Adjustment Limit	Half Defect Limit	Full Defect Limit
30	8 1/8 (206 mm)	2 1/4 (57.2 mm)	2 3/8 (60.3 mm)	2 1/2 (63.5 mm)

NOTE: This chamber has three air lines and is found on motorcoaches.

NOTE: A brake found at the adjustment limit is not a defect for the purposes of the 20 percent rule.

WEDGE BRAKE DATA

The combined movement of both brake shoe lining scribe marks shall not exceed 1/8 inch (3.2 mm).

(5) Drum (Cam-Type and Wedge) Air Brakes

- (a) Missing or broken brake shoe, lining, return spring (shoe or chamber), anchor pin, spider, cam roller, camshaft, pushrod, yoke, clevis pin, clevis pin retainer (e.g., cotter pin), brake adjuster, parking brake power spring, or air chamber mounting bolt. (393.48(a))

Inspection Bulletin 2006-01 – Camshaft Bushings

- (b) Loose air chamber, spider, or camshaft support bracket. (393.48(a))

- (c) Defective Lining Conditions

- i. Lining cracks or voids that exceed 1/16 inch (1.6 mm) in width observable on the edge of the lining. (393.47(a))

Operational Policy 15 – Inspection/Regulatory Guidance: Regulatory Guidance 1.b.(1) – Cracks/Rust Jacking

- ii. Portion of a lining segment missing such that a fastening device (rivet or bolt) is exposed when viewing the lining from the edge. (393.47(a))
 - iii. Crack that exceeds 1-1/2 inch (38.1 mm) in length. (393.47(a))
 - iv. Loose lining segment. (Approximately 1/16 inch (1.6 mm) or more movement.) (393.47(a))
 - v. Complete lining segment missing. (393.47(a))
 - vi. The friction surface of the brake drum and the brake friction material are contaminated by oil or grease. (393.47(a))

NOTE: Refer to “Wheels, Rims and Hubs” if wheel seal is actively leaking.

- vii. Lining thickness less than 1/4 inch (6.4 mm) or worn into the wear indicator if lining is so marked, measured at the shoe center. (393.47(d)(2))

Inspection Bulletin 2007-01 – Express Brake International, Inc. – Segmented Brake Linings

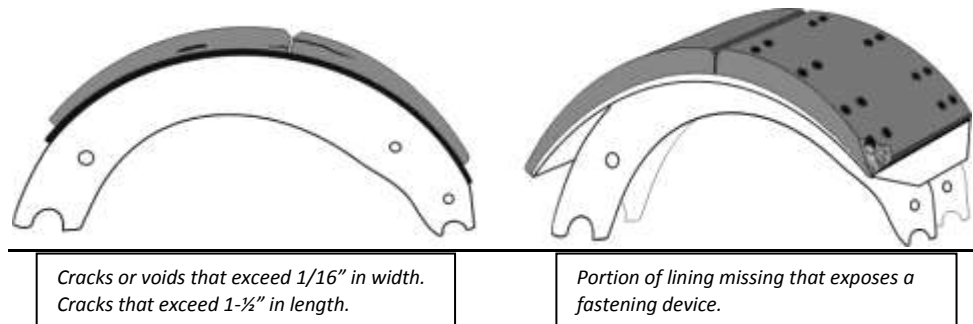

(6) Air Disc Brakes (Exposed Pushrods and Direct Coupled – Air Chamber to Caliper)

- (a) Missing or broken caliper, brake pad, pad retaining component, pushrod, yoke, clevis pin, clevis pin retainer (e.g., cotter pin), brake adjuster, parking brake power spring, chamber return spring, or air chamber mounting bolt. (393.48(a))
- (b) Loose or missing brake chamber or caliper mounting bolt. (393.48(a))
- (c) Rotor has evidence of metal to metal contact on the friction surface. (393.47(d)(2))
- (d) Rotor has severe rusting on the rotor friction surface on either side (light rusting on the friction surface is normal). (393.48(a))
- (e) The friction surface of the brake rotor and the brake friction material are contaminated by oil or grease. (393.47(a))

NOTE: Refer to “Wheels, Rims and Hubs” if wheel seal is actively leaking.

- (f) Brake pad thickness less than 1/16 inch (1.6 mm) or to wear indicator if pad is so marked. (393.47(d)(2))

(7) Hydraulic and Electric Brakes

- (a) Missing or broken caliper, pad retaining component, brake pad, shoe, or lining. (393.48(a))
- (b) Loose or missing brake caliper mounting bolt. (393.48(a))
- (c) Movement of the caliper within the anchor plate, in the direction of wheel rotation, exceeds 1/8 inch (3.2 mm). (393.48(a))

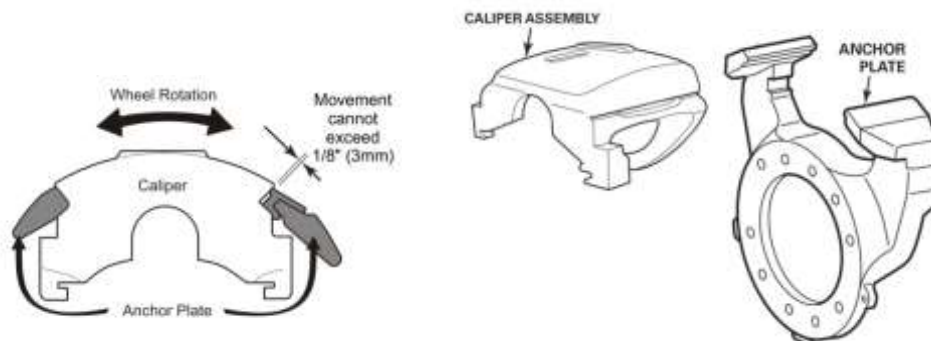

- (d) Rotor or drum has evidence of metal to metal contact on the friction surface. (393.47(d)(2))
- (e) Rotor has severe rusting on the rotor friction surface on either side (light rusting on the friction surface is normal). (393.48(a))
- (f) Friction surface of the brake rotor and the brake friction material are contaminated by oil, grease, or brake fluid. (393.47(a))

NOTE: Refer to “Wheels, Rims and Hubs” if wheel seal is actively leaking.

- (g) Lining or pad with a thickness 1/16 inch (1.6 mm) or less for disc or drum brakes. (393.47(d)(2))

b. Front Steering Axle(s) Brakes

In addition to being included in the 20 percent criterion, the following place a vehicle in an out-of-service condition:

- (1) Any inoperative brake (such as any brake lining/pad failing to move or contact braking surface upon application) or missing brake on either wheel of any steering axle of any vehicle equipped or required to be equipped with steering axle brakes, including the dolly and front axle of a full trailer. This includes tractors required to have steering axle brakes. (Missing - 393.42(a) or Inoperative - 393.48(a))

(2) Drum (Cam-Type and Wedge) Air Brakes – (Front Steering Brakes)

- (a) Mismatched air chamber sizes. (393.47(b))

NOTE: Mismatched air chamber size excludes long stroke air chamber versus regular stroke air chamber and excludes differences in design type such as type 20 clamp versus type 20 rotochamber. A bolt chamber with any other chamber type is a mismatch.

- (b) Mismatched brake adjuster length. (393.47(c))

(c) Defective Lining Conditions

- i. Lining cracks or voids that exceed 1/16 inch (1.6 mm) in width observable on the edge of the lining. (393.47(a))

***Operational Policy 15 – Inspection/Regulatory
Guidance: Regulatory Guidance 1.b.(1) – Cracks/Rust
Jacking***

- ii. Portion of a lining segment missing such that a fastening device (rivet or bolt) is exposed when viewing the lining from the edge. (393.47(a))

- iii. Crack that exceeds 1-1/2 inch (38.1 mm) in length. (393.47(a))
- iv. Loose lining segment. (Approximately 1/16 inch (1.6 mm) or more movement.) (393.47(a))
- v. Complete lining segment missing. (393.47(a))
- vi. The friction surface of the brake drum and the brake friction material are contaminated by oil or grease. (393.47(a))

NOTE: Refer to “Wheels, Rims and Hubs” if wheel seal is actively leaking.

- vii. Lining with a thickness less than 3/16 inch (4.8 mm) for a shoe with a continuous strip of lining or 1/4 inch (6.4 mm) for a shoe with two lining blocks for drum brakes or worn into the wear indicator if lining is so marked. (393.47(d)(1))
Inspection Bulletin 2007-01 – Express Brake International, Inc. – Segmented Brake Linings

(3) Air Disc Brakes (Exposed Pushrods and Direct Coupled – Air Chamber to Caliper) – (Front Steering Axle)

- (a) Mismatched air chamber sizes. (393.47(b))

NOTE: Mismatched air chamber size excludes long stroke air chamber versus regular stroke air chamber. A mismatch on an air disc brake exists only when there is measurable difference in air chamber clamp sizes.

- (b) Mismatched brake adjuster length. (393.47(c))
- (c) Missing brake pad. (393.47(a))
- (d) Rotor has evidence of metal to metal contact on the friction surface. (393.47(d)(1))
- (e) Rotor has severe rusting on the rotor friction surface on either side (light rusting on the friction surface is normal). (393.48(a))
- (f) The friction surface of the brake rotor and the brake friction material are contaminated by oil or grease. (393.47(a))

NOTE: Refer to “Wheels, Rims and Hubs” if wheel seal is actively leaking.

- (g) Brake pad thickness less than 1/16 inch (1.6 mm) or to wear indicator if lining is so marked. (393.47(d)(1))

- (4) Hydraulic Brakes – (Front Steering Brakes)
- (a) Missing lining or pad. (393.47(a))
 - (b) Loose or missing brake caliper mounting bolt. (393.48(a))
 - (c) Movement of the caliper within the anchor plate, in the direction of wheel rotation, exceeds 1/8 inches (3.2 mm). (393.48(a))
 - (d) Rotor has evidence of metal to metal contact on the friction surface. (393.47(d)(1))
 - (e) Rotor has severe rusting on the rotor friction surface on either side (light rusting on the friction surface is normal). (393.48(a))
 - (f) The friction surface of the brake drum or rotor and the brake friction material are contaminated by oil, grease, or brake fluid. (393.47(a))
- NOTE:** Refer to “Wheels, Rims and Hubs” if wheel seal is actively leaking.
- (g) Pad with a thickness 1/16 inch (1.6 mm) or less for disc brakes. (393.47(d)(1))

End of 20 Percent Brake Criterion

c. Spring Brake Chambers

Any non-manufactured holes or cracks in the spring brake housing section of a parking brake. (396.3(a)(1))

d. Trailer Breakaway and Emergency Braking

- (1) Missing or inoperable breakaway braking system on a trailer or converter dolly. (393.43(d))
- (2) A breakaway system not directly attached to the towing vehicle. (393.43(d))
- (3) On any trailer equipped with spring brakes; more than 25 percent of the spring brakes are inoperative. (393.43(d))

e. Parking Brake

No brakes on the vehicle or combination are applied upon actuation of the parking brake control, including driveline hand controlled parking brakes. (393.41)

f. Brake Smoke/Fire

Brake malfunction causing smoke or fire to emit from the wheel end. (393.48(a))

Example: Brake lining continuously in contact with brake drum or rotor.

NOTE: This does not include overheating due to severe brake use.

NOTE: Refer to “Wheels, Rims and Hubs”; as the cause may either be the brakes or a problem in the hub and bearing area.

g. Brake Drums or Rotors (Discs)

- (1) ** Any portion of the drum has any external crack, or has any crack that opens upon brake application. (393.47(a))
- (2) ** Any rotor (disc) with a crack in length of more than 75 percent of the friction surface and passes completely through the rotor to the center vent from either side or completely through a solid rotor. (393.47(a))
- (3) A rotor surface is worn to or through center vents. (393.47(g))
- (4) Any portion of the drum or rotor (discs) missing or in danger of falling away. (393.47(a))

** NOTE: Do not confuse short hairline heat check cracks with flexural cracks.

h. Air Brake Hose/Tubing

- (1) Any damage extending through the reinforcement ply. (393.45(a)) (as per 4 or 5 below)

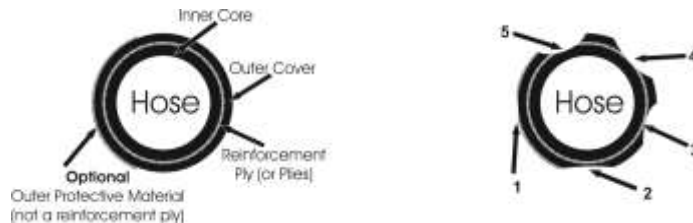

Ref #	Visual Characteristics	OOS Status
1	Wear extends into outer protective material.	Not “OOS”
2	Wear extends through outer protective material into outer cover.	Not “OOS”
3	Wear makes reinforcement ply visible, but ply is intact.	Not “OOS”
4	Reinforcement ply is visible and ply is frayed, severed, or cut through.	“OOS”
5	Wear extends through reinforcement ply.	“OOS”

Operational Policy 15 – Inspection/Regulatory Guidance: Regulatory Guidance 1.b.(2) – Air Hose Violations

NOTE: Rubber impregnated fabric cover is not a reinforcement ply.

NOTE: Thermoplastic nylon tube may have braid reinforcement or color difference between cover and inner tube. Exposure of second color is an out-of-service condition.

- (2) Bulge/swelling when air pressure is applied. (393.45(a))
- (3) Audible air leak at other than a proper connection. (393.45(a))
Inspection Bulletin 2010-05 – MCI Buses with Detroit Diesel Engines

Operational Policy 15 – Inspection/Regulatory Guidance: OOS Frequently Asked Questions 1.a.(1) – Proper Connections

Operational Policy 15 – Inspection/Regulatory Guidance: Regulatory Guidance 1.b.(3) – Air Leaks

- (4) Improperly joined, such as a splice made by sliding the hose ends over a piece of tubing and clamping the hose to the tube. (393.45(a))
- (5) Damaged by heat, broken, or crimped in such a manner as to restrict air flow. (393.45(a))

i. Air Pressure Gauge

Inoperative or defective primary or secondary air pressure gauge. (393.51(c))

j. Low Air Pressure Warning Device

Low air pressure warning device missing, inoperative, or does not operate continuously if either the primary or secondary reservoir is 55 psi (379 kPa) and below, or 1/2 of the governor cut-out pressure, whichever is less. (393.51(c))

NOTE: If either an audible or visual warning device is working as required, vehicle should not be declared out-of-service.

k. Air Loss Rate

If an air leak is discovered and either the primary or secondary reservoir pressure is not maintained when: (396.3(a)(1))

- (1) Governor is cut-in;
- (2) Reservoir pressure is between 80 – 90 psi (551 – 620 kPa);
- (3) Engine is at idle; and,
- (4) Service brakes are either fully applied or released.

I. Tractor Protection System

Inoperable or missing tractor protection system components including a tractor protection valve and/or trailer supply valve. (393.43(b))

NOTE: An inoperative tractor protection system is defined as one of the following conditions:

1. The trailer supply valve fails to close before pressure drops below 20 psi (138 kPa) in either the primary or secondary system.
2. When air escapes from either glad hand when brakes are applied after the tractor protection valve has closed.

Inspection Bulletin 2010-01 – Tractor Protection Systems

m. Air Reservoir (Tank)

An air reservoir (tank) separated at either end from the attachment point(s) allowing movement of more than 1 inch (25.4 mm) in any direction. (396.3(a)(1))

n. Air Compressor

(Normally to be inspected when readily visible or when conditions indicate compressor problems.)

- (1) Loose compressor mounting bolts. (396.3(a)(1))
- (2) Cracked, broken, or loose pulley. (396.3(a)(1))
- (3) Cracked or broken mounting brackets, braces, or adapters. (396.3(a)(1))

o. Hydraulic Brakes

- (1) The fluid level in any master cylinder reservoir is less than 1/4 full or below minimum marking. (396.3(a)(1))

NOTE: Normally to be inspected when readily visible or problems are apparent.

- (2) Hydraulic or vacuum lines, hoses, or connections are restricted, crimped, broken or damaged through the outer reinforcement ply.
(Restricted/Crimped/Broken - 393.45(a) or Damaged - (393.45(b)(2))

NOTE: Rubber impregnated fabric cover is not a reinforcement ply.

- (3) Any observable seepage, bulge or swelling on a brake hose under application pressure. (393.45(a))
- (4) Improperly joined, such as a splice made by sliding a hose/tube end over the brake line and clamping the hose to the brake line. (393.45(a))

- (5) Any observable leaking hydraulic fluid in the brake system upon full application. (393.45(a))
- (6) No pedal travel reserve with engine running upon full brake application. (393.40(b))
- (7) Brake power assist unit is inoperative. (396.3(a)(1))
- (8) Hydraulic power brake (HPB) unit is inoperative. (396.3(a)(1))
- (9) Brake failure warning system is missing, inoperative, disconnected, defective or activated while the engine is running with or without brake application. (393.51(b))
- (10) The hydraulic brake backup system is inoperative. (396.3(a)(1))

Inspection Bulletin 2012-04 – Hydraulic Brake System Inspection Procedures

p. Vacuum Brakes

- (1) Insufficient vacuum reserve to permit one full brake application after engine is shut off. (393.50(b))
- (2) Vacuum hose(s) or line(s) restricted, abraded (chafed) through outer cover-to-cord ply, crimped, cracked, broken, or has collapse of vacuum hose(s) when vacuum is applied. (393.45(b)(2))

q. Performance-Based Brake Test (PBBT)

Failing to develop a total brake force as a percentage of gross vehicle or combination weight of 43.5 or more on an approved PBBT. (393.52(a))

NOTE: The out-of-service notice will be satisfactorily completed: (1) If an approved PBBT is available, the vehicle shall be retested on an approved PBBT and achieve a total brake force as a percentage of gross vehicle or combination weight of 43.5 or more; or (2) If an approved PBBT is unavailable, each of the brake fault areas identified on the inspection report shall be inspected and repaired.

NOTE: In the United States, an approved PBBT must meet the FMCSA functional specifications 65 FR 48799, August 9, 2000.

***2. CARGO SECUREMENT**

- a. Part(s) of a vehicle or condition of loading such that the spare tire or any part of the load, cargo or dunnage can fall onto the roadway. (Vehicle Components/Dunnage - 392.9(a)(2) or General Cargo - 393.100(b))
- b. Articles of cargo that are likely to roll are not restrained by chocks, wedges, a cradle or other equivalent means to prevent rolling. (393.106(c)(1))

- c. Articles of cargo placed beside each other and secured by transverse tiedowns are not in direct contact with each other and are not prevented from shifting towards each other while in transit. (393.106(c)(2))
- d. When the aggregate working load limit of the securement devices being used is less than 1/2 the weight of the cargo being secured. (393.106(d))

NOTE: Equivalent means of securement (e.g., vehicle structures, dunnage, dunnage bags, shoring bars, etc.) may be used to comply; not all cargo must be “tied down” with chains, webbing, wire rope, cordage, etc.

- e. Articles of cargo not blocked or positioned to prevent movement in the forward direction by a headerboard, bulkhead, other cargo that is positioned to prevent movement, or other appropriate blocking devices, is not secured by at least:
 - (1) One tiedown for articles 5 feet (1.52 m) or less in length, and 1,100 pounds (500 kg) or less in weight. (393.110(b)(1))
 - (2) Two tiedowns if the article is:
 - (a) 5 feet (1.52 m) or less in length and more than 1,100 pounds (500 kg) in weight; or, (393.110(b)(2)(i))
 - (b) Longer than 5 feet (1.52 m) but less than or equal to 10 feet (3.04 m) in length, irrespective of the weight. (393.110(b)(2)(ii))
 - (3) Two tiedowns if the article is longer than 10 feet (3.04 m) and one additional tiedown for every 10 feet (3.04 m) of article length, or fraction thereof, beyond the first 10 feet (3.04 m) of length. (393.110(b)(3))

NOTE: Tiedowns shall be positioned as follows:

- i. Tiedowns spaced 10 feet (3.04 m) apart along the length of the vehicle; or,
 - ii. A tiedown in every 10 foot (3.04 m) segment of the cargo; or,
 - iii. To accommodate anchor points or cargo damage considerations, tiedowns may be spaced or grouped at lengths greater or less than 10 feet (3.04 m).
- f. Article(s) of cargo that is blocked, braced or immobilized to prevent movement in the forward direction by a headerboard, bulkhead, other articles which are adequately secured or by an appropriate blocking or immobilization method, is not secured by at least one tiedown for every 10 feet (3.04 m) of article length, or fraction thereof. (393.110(c))

NOTE: Tiedowns shall be positioned as follows:

- i. Tiedowns spaced 10 feet (3.04 m) apart along the length of the vehicle; or,
- ii. A tiedown in every 10 foot (3.04 m) segment of the cargo; or,
- iii. To accommodate anchor points or cargo damage considerations, tiedowns may be spaced or grouped at lengths greater or less than 10 feet (3.04 m).

Operational Policy 15 – Inspection/Regulatory Guidance: Regulatory Guidance 2.b.(1) – Bungee Cord/Trap Straps

Operational Policy 15 – Inspection/Regulatory Guidance: Regulatory Guidance 2.b.(4) – Hay and Straw Bales

Operational Policy 15 – Inspection/Regulatory Guidance: Regulatory Guidance 2.b.(5) – Stretch Film and/or Shrink-Wrap

Operational Policy 15 – Inspection/Regulatory Guidance: Regulatory Guidance 2.b.(7) – Friction Mats

g. Logs

Not secured per the commodity specific securement requirements. (393.116)

h. Dressed Lumber or Similar Building Products

Not secured per the commodity specific securement requirements. (393.118)

i. Metal Coils

Not secured per the commodity specific securement requirements. (393.120)

Operational Policy 15 – Inspection/Regulatory Guidance: Regulatory Guidance 2.b.(3) – Metal Coil Exemption

j. Paper Rolls

Not secured per the commodity specific securement requirements. (393.122)

k. Concrete Pipe

Not secured per the commodity specific securement requirements. (393.124)

l. Intermodal Containers

Not secured per the commodity specific securement requirements. (393.126)

Inspection Bulletin 2011-03 – Securement of an Intermodal Container on an Intermodal Chassis

m. Automobiles, Light Trucks and Vans
Not secured per the commodity specific securement requirements. (393.128)

n. Heavy Vehicles, Equipment and Machinery
Not secured per the commodity specific securement requirements. (393.130)

***Operational Policy 15 – Inspection/Regulatory Guidance: OOS
Frequently Asked Questions 2.a.(1) – Auxiliary Equipment***

o. Flattened or Crushed Vehicles
Not secured per the commodity specific securement requirements. (393.132)

***Operational Policy 15 – Inspection/Regulatory Guidance: Regulatory
Guidance 2.b.(6) – Cubed/Crushed Cars***

p. Roll-on/Roll-off or Hook Lift Containers
Not secured per the commodity specific securement requirements. (393.134)

q. Large Boulders
Not secured per the commodity specific securement requirements. (393.136)

A tiedown or anchor point that is found to have a defect in the load bearing portion of the tiedown as outlined in the “Tiedown Defect Table” will not be considered when determining the weight and/or length requirements.

Individual tiedowns being used to secure cargo found in conditions outlined in the table are not out-of-service, only violations. If these tiedowns are required to meet the requirements for length and/or weight, the out-of-service condition(s) will be recorded under the applicable weight and/or length and/or the specific commodity. (393.104)

***Operational Policy 15 – Inspection/Regulatory Guidance: Regulatory Guidance 2.b.(2) –
Violation Guidance for Damaged Tiedowns***

TIEDOWN DEFECT TABLE

Chain

- Loose chain.
- Contains nicks, gouges, abrasions or broken, cracked, twisted, bent, knotted, or stretched links.

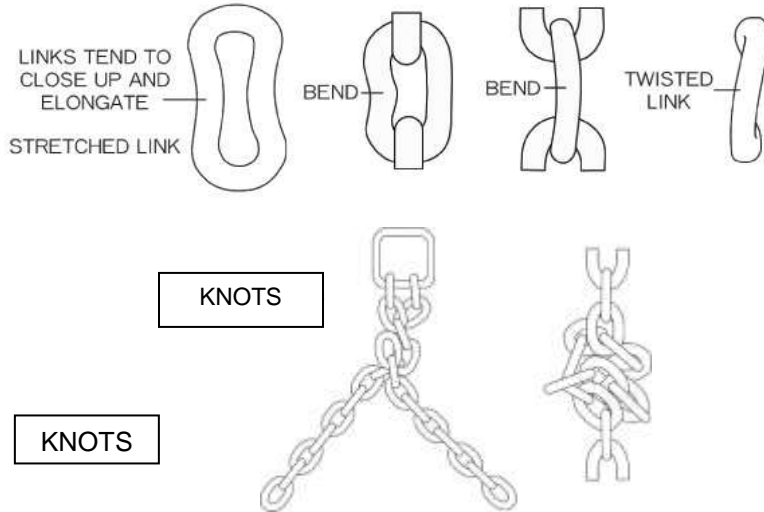

- Excessive wear causing a 20 percent or more reduction in original material thickness.

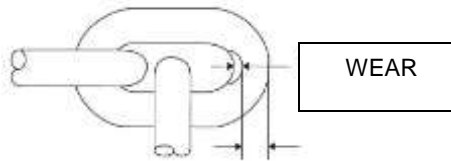

- Any weld(s) on chain, to repair broken/damaged links or to join links.

NOTE: Repairs. Links of the clevis variety, having strength equal to or greater than the nominal chain are acceptable.

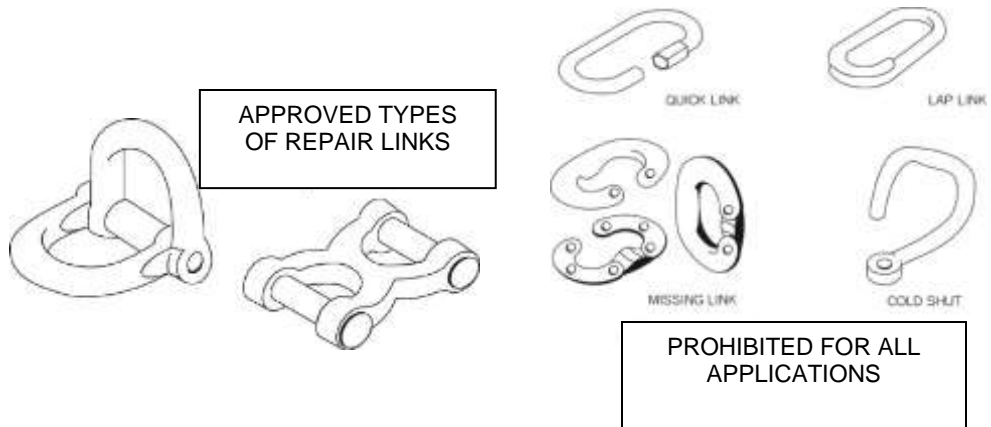

- Chain is damaged as a result of missing edge protection.

TIEDOWN DEFECT TABLE

Wire Rope

- Loose wire rope.
- Kinks, bird caging, popped core, or knots in the working section of the wire rope.



- Discoloration from excessive heat or electric arc in the eye or main body of the wire rope.

- Corrosion with pitting of the external or internal wires.

- More than 11 broken wires in 6 diameters of length. For example: with 1/2 inch (13 mm) wire rope, over 11 broken wires in (6 x 1/2) or 3 inches in length (6 x 13 = 78 mm).



- More than three broken wires in any one strand.



- More than two broken wires at the end connection or fitting.

NOTE: Repairs. Wire rope used in tiedown assemblies shall not be repaired or spliced. (Eye splices and back splices are acceptable.)

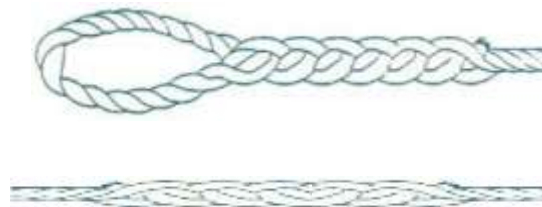



EYE
SPLICE

BACK
SPLICE

- Wire rope is damaged as a result of missing edge protection.

***TIEDOWN DEFECT TABLE**

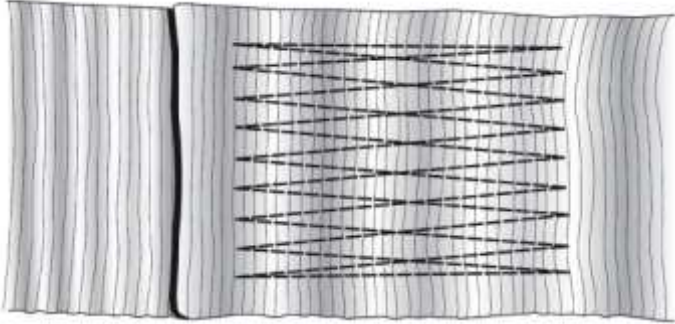
<p>Cordage (Fiber Rope)</p>	<ul style="list-style-type: none"> • Loose cordage (fiber rope). • Burned or melted fibers except on heat-sealed ends. • Ineffective knots formed for the purpose of connecting or repairing binders. • ** Evidence of excessive wear in exterior or interior fibers. • ** Any evidence of loss of strength, such as a marked reduction in diameter. <p>** NOTE: Effective diameter of cordage reduced by 20 percent is excessive. Repairs: Cordage used in tiedown assemblies shall not be repaired. (Separate lengths of cordage properly spliced together are not considered repairs.)</p> <div style="display: flex; justify-content: space-around; align-items: center;"> <div style="text-align: center;">  </div> <div style="border: 1px solid black; padding: 5px; text-align: center;"> <p>CHAFED AND FRAYED YARNS</p> </div> </div> <div style="display: flex; justify-content: space-around; align-items: center; margin-top: 10px;"> <div style="text-align: center;">  </div> <div style="border: 1px solid black; padding: 5px; text-align: center;"> <p>MINOR ABRASION OR CHAFING OKAY</p> </div> </div>
<p>*Synthetic Webbing</p>	<ul style="list-style-type: none"> • Cordage (fiber rope) is damaged as a result of missing edge protection. • Loose synthetic webbing. • The tiedown contains separation of its load carrying stitch pattern(s) in excess of 1/4 of the total stitch area. <p align="center">Graphic of example of a load bearing stitch pattern at hook end.</p> <div style="text-align: center; margin: 10px 0;">  </div> <ul style="list-style-type: none"> • A fitting, tensioning device, or other hardware (other than the webbing) is broken, obviously sprung, bent, twisted, or contains a visible crack or a significant nick or gouge. • The tiedown contains a knot, repair, splice, or any other apparent defect (i.e., crushed areas, damaged loop ends, severe abrasions, etc.).

***TIEDOWN DEFECT TABLE**

*Synthetic Webbing

- The tiedown contains cut(s), burn(s), and/or hole(s) through the webbing which total more than that shown in the Defect Classification Table.

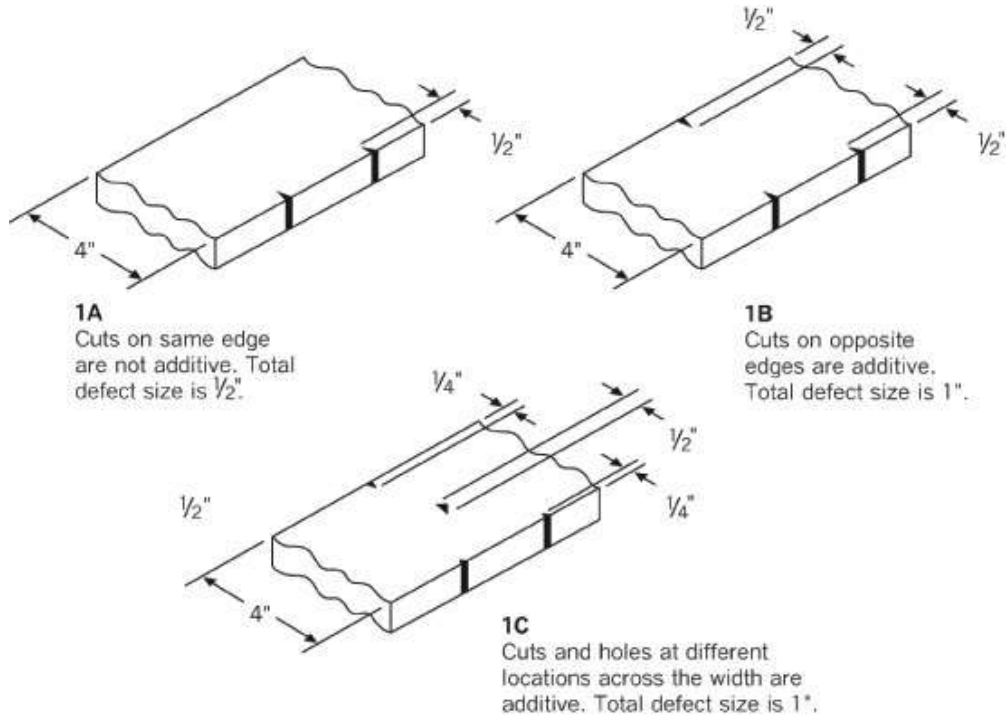

DEFECT CLASSIFICATION TABLE
Total Defect Size

<u>Web Size</u> Inches (mm)	<u>*Defect Range</u> Inches (mm)
4 (100)	Larger than $\frac{3}{4}$ (19)
3 (75)	Larger than $\frac{5}{8}$ (16)
2 (50)	Larger than $\frac{3}{8}$ (10)
1.75 (45)	Larger than $\frac{3}{8}$ (10)

All cut(s), burn(s), and/or hole(s) through the webbing are additive across the width of the strap face for its entire effective length. But only one defect is additive for any specific width.

NOTE: Repairs. Webbing used in tiedown assemblies shall not be repaired or spliced.

- Synthetic webbing is damaged as a result of missing edge protection.

TIEDOWN DEFECT TABLE	
Steel Strapping	<ul style="list-style-type: none"> • Loose steel strapping.
	<ul style="list-style-type: none"> • Steel strappings over 1 inch (25 mm) in width not having at least two pair of crimps in each seal.
	<ul style="list-style-type: none"> • Steel strappings arranged in an end-over-end lap joint not sealed with at least two seals.
	<ul style="list-style-type: none"> • Obviously damaged or distorted steel strappings.
	<ul style="list-style-type: none"> • Steel Strapping is damaged as a result of missing edge protection.
Fitting / Attachment / Tensioning Device	<ul style="list-style-type: none"> • Obvious reduction of section through wear or corrosion.
	<ul style="list-style-type: none"> • Obviously distorted or stretched load binders and fittings.
	<ul style="list-style-type: none"> • Hooks opened in the throat beyond the original parallel throat opening.
	<ul style="list-style-type: none"> • Any missing required component.
	<ul style="list-style-type: none"> • Obvious twisting out of the plane of the fitting.
	<ul style="list-style-type: none"> • A fitting, tensioning device, or other hardware is broken, obviously sprung, bent, twisted, or contains a visible crack or a significant nick or gouge.
	<ul style="list-style-type: none"> • Welding or discoloration from excessive heat. <p style="margin-left: 40px;">NOTE: Some winches are designed to be welded to the truck bed.</p>
	<ul style="list-style-type: none"> • Any visible cracks.
	<ul style="list-style-type: none"> • Any slippage detectable at a wire rope "cable clamp". <p style="margin-left: 40px;">NOTE: End fittings may be replaced with clevis type.</p>
	<ul style="list-style-type: none"> • Any visible cracks.
Anchor Point	<ul style="list-style-type: none"> • Broken or cracked side or pocket rails, supports, or welds.
	<ul style="list-style-type: none"> • Rails bent or distorted where hooks or fittings attach.
	<ul style="list-style-type: none"> • Floor rings nicked, gouged, worn, twisted, bent, stretched, or with broken welds.

3. COUPLING DEVICES

NOTE: The following criterion only applies when the device is in use.

NOTE: "Parent Metal" is the part (angle iron, pivot bracket, mounting plate, slider base plate, fifth wheel plate, upper coupler)

"Non-Parent Metal" is weld material.

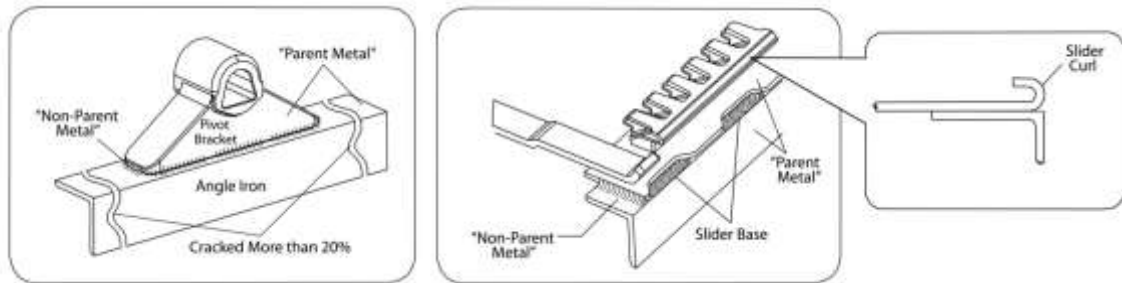

a. Fifth Wheels: (Lower Coupler Assembly)

(1) Mounting to Frame

- (a) More than 20 percent of fasteners on either side of the vehicle are missing or ineffective. (393.70(b)(1)(i))
- (b) Any movement between mounting components. (393.70(b)(1)(i))
- (c) A crack in the mounting angle iron (parent metal) extending more than 20 percent of the distance across the metal in the direction of the crack. (393.70(b)(1)(i))
- (d) A crack, or a gap caused by corrosion, that is 1/8 inch (3.2 mm) or more in width. (393.70(b)(1)(i))
- (e) More than 20 percent of the total length of all the original welds (including fore and aft welds) are cracked on either side of the vehicle. (393.70(b)(1)(i))
- (f) A repair weld is cracked. (393.70(b)(1)(i))

(2) Mounting Plates & Pivot Brackets

- (a) More than 20 percent of fasteners on either side of the vehicle are missing or ineffective. (393.70(b)(1)(i))
- (b) A crack in the mounting plate or pivot bracket (parent metal) extending more than 20 percent of the distance across the metal in the direction of the crack. (393.70(b)(1)(i))
- (c) A crack, or a gap caused by corrosion, that is 1/8 inch (3.2 mm) or more in width. (393.70(b)(1)(i))

- (d) More than 20 percent of the total length of all the original welds (including fore and aft welds) are cracked on either side of the vehicle. (393.70(b)(1)(i))
- (e) A repair weld is cracked. (393.70(b)(1)(i))
- (f) More than 3/8 inch (9.5 mm) horizontal movement between pivot bracket pin and bracket. (393.70(b)(1)(i))
- (g) Pivot bracket pin missing or not secured. (393.70(b)(1)(i))

(3) Sliders

- (a) More than 25 percent of latching fasteners on either side of the vehicle are ineffective. (393.70(b)(1)(i))
- (b) Any fore or aft stop missing or not securely attached. (393.70(b)(1)(i))

NOTE: A moveable fifth wheel that is secured with vertical pins does not need fore or aft stops.

- (c) Movement of more than 3/8 inch (9.5 mm) between slide bracket and slide base. (393.70(b)(1)(i))
- (d) A slide curl is broken, cracked or repaired by welding. (393.70(b)(1)(i))

(4) Operating Handle

Operating handle not in closed or locked position. (393.70(b)(2))

(5) Fifth Wheel Plate

- (a) A crack in the fifth wheel plate (parent metal) extending more than 20 percent of the distance across the metal in the direction of the crack. (396.3(a)(1))
- (b) A crack, or a gap caused by corrosion, that is 1/8 inch (3.2 mm) or more in width. (396.3(a)(1))
- (c) A repair weld is cracked. (396.3(a)(1))

EXCEPTIONS: (1) Cracks in fifth wheel approach ramps, and (2) casting shrinkage cracks in the ribs of the body of a cast fifth wheel.

(6) Locking Mechanism

Locking mechanism parts missing, broken, or deformed to the extent that the kingpin is not securely held. (393.70(b)(1)(i))

b. Upper Coupler Assembly: (Including Kingpin)

- (1) Horizontal movement between the upper and lower fifth wheel halves exceeds 1/2 inch (12.5 mm). (396.3(a)(1))

Operational Policy 15 – Inspection/Regulatory Guidance: Regulatory Guidance 3.b.(1) – Fifth Wheel Play

- (2) Kingpin can be moved by hand in any direction. (396.3(a)(1))

NOTE: This item is to be used when uncoupled semitrailers are encountered, such as at a terminal inspection, and it is impossible to check item (1) above. Kingpins in coupled vehicles are to be inspected using item (1) above and items (3) and (4) below. Vehicles are not to be uncoupled.









- (3) Kingpin not properly engaged. (393.70(b)(2))
- (4) Any trailer with a bolted upper coupler, which has fewer effective bolts than shown below. (393.70(b)(1)(i))
- (5) A crack in the upper coupler (parent metal) extending more than 20 percent of the distance across the metal in the direction of the crack. (393.70(b)(1)(i))
- (6) A crack, or a gap caused by corrosion, that is 1/8 inch (3.2 mm) or more in width. (393.70(b)(1)(i))
- (7) More than 20 percent of the total length of all the original welds are cracked on either side, front or back of the upper coupler. (393.70(b)(1)(i))
- (8) A repair weld cracked. (393.70(b)(1)(i))

Minimum Number of Bolts per Side Based on Type & Size** of Bolt						
Maximum Trailer GVWR	ASTM A325 Type 1,2 & 3 (Metric 5.8)		SAE J429 Grade 5 (Metric 8.8)		SAE J429 Grade 8 (Metric 10.9)	
	1/2" (12 mm)	5/8" (16 mm) or larger	1/2" (12 mm)	5/8" (16 mm) or larger	1/2" (12 mm)	5/8" (16 mm) or larger
68,000 lbs (30,844 kg) or less	6	4	6	4	5	4
68,001 - 85,000 lbs (30,845 - 38,555 kg)	8	5	8	5	7	5
85,001 - 105,000 lbs (38,556 - 47,627 kg)	10	6	10	6	8	5

** Bolt size refers to the outside diameter of the thread.

- 1/2 inch bolts have 3/4 inch heads and nuts
- 5/8 inch bolts have 15/16 inch heads and nuts
- 12 mm bolts have 19 mm heads and nuts
- 16 mm bolts have 24 mm heads and nuts

BOLT HEAD GRADE IDENTIFICATION MARKING

ASTM A325 Type 1	ASTM A325 Type 2	ASTM A325 Type 3	SAE J429 Grade 5	SAE J429 Grade 8	Metric 5.8	Metric 8.8	Metric 10.9
							

c. Pintle Hooks

Mounting and Integrity

- (1) Loose mounting, missing or ineffective fasteners, or insecure latch. (Trailer - 393.70(c) or Driveaway - 393.71(h))

NOTE: A fastener is not considered missing if there is an empty hole in the device but no corresponding hole in the frame and vice versa.

- (2) Cracks anywhere in the pintle hook assembly including mounting surface and frame cross member. (Trailer - 393.70(c) or Driveaway - 393.71(h))
- (3) Any welded repairs to the pintle hook assembly. (Trailer - 393.70(c) or Driveaway - 393.71(h))
- (4) Section reduction visible when coupled. (Trailer - 393.70(c) or Driveaway - 393.71(h))

NOTE: No part of the horn should have any section reduced by more than 20 percent. If wear can be seen when the hook and eye are coupled, it is possible that either this condition or section reduction in the draw bar eye exists.

Operational Policy 15 – Inspection/Regulatory Guidance: Regulatory Guidance 3.b.(2) – Pintle Hook Violations

d. Drawbar Eye

Mounting and Integrity

- (1) Any cracks in attachment welds or drawbar eye. (Trailer - 393.70(c) or Driveaway - 393.71(h))
- (2) Any missing or ineffective fasteners. (Trailer - 393.70(c) or Driveaway - 393.71(h))
- (3) Any welded repairs to the drawbar eye. (Trailer - 393.70(c) or Driveaway - 393.71(h))
- (4) Section reduction visible when coupled. (Trailer - 393.70(c) or Driveaway - 393.71(h))

NOTE: No part of the eye should have any section reduced by more than 20 percent. If wear can be seen when the hook and eye are coupled, it is possible that either this condition or section reduction in the pintle hook exists.

e. Drawbar/Tongue

(1) Slider (Power/Manual)

- (a) Ineffective latching mechanism. (Trailer - 393.70(c) or Driveaway - 393.71(h))
- (b) Missing or ineffective stop. (Trailer - 393.70(c) or Driveaway - 393.71(h))
- (c) Movement of more than 1/4 inch (6.4 mm) between the slider and housing. (Trailer - 393.70(c) or Driveaway - 393.71(h))
- (d) Any leaking air or hydraulic cylinders, hoses, or chambers (other than slight oil weeping normal with hydraulic seals). (Trailer 393.70(c) or Driveaway - 393.71(h))

(2) Integrity

- (a) Any cracks. (Trailer - 393.70(c) or Driveaway - 393.71(h))
- (b) Movement of 1/4 inch (6.4 mm) between sub frame and drawbar at point of attachment. (Trailer - 393.70(c) or Driveaway - 393.71(h))

f. Safety Devices

- (1) Missing. (Trailer - 393.70(d) or Driveaway - 393.71(h)(10))
- (2) Unattached or incapable of secure attachment. (Trailer - 393.70(d) or Driveaway - 393.71(h)(10))
- (3) Improper repairs to chains and hooks including welding, wire, small bolts, rope, and tape. (Trailer - 393.70(d) or Driveaway - 393.71(h)(10))
- (4) Chain or Wire Rope: Damaged or defective to the same extent as the criterion used for chain or wire rope defects described in the "Cargo Securement – Tiedown Defect Table". (Trailer - 393.70(d) or Driveaway - 393.71(h)(10))

EXCEPTION: Quick-link(s) that are fully engaged, and marked with a manufacturer's minimum breaking strength/force (MBS/MBF) rating on the link that is equal to or greater than the GVW of the trailer(s), are acceptable for use in a safety device.

g. Hitch Systems (Excluding Fifth Wheels and Pintle Hooks)

Mounting and Integrity

- (1) Loose mounting, missing or ineffective fasteners, or insecure latch. (Trailer - 393.70(c) or Driveaway - 393.71(h))

NOTE: A fastener is not considered missing if there is an empty hole in the device but no corresponding hole in the frame and vice versa.

- (2) Cracks anywhere in the hitch system including mounting surface and frame cross member. (Trailer - 393.70(c) or Driveaway - 393.71(h))
- (3) Any welded repairs to the ball, ball-socket, pin or eye. (Trailer - 393.70(c) or Driveaway - 393.71(h))

h. Saddle-Mounts (Method of Attachment)

- (1) Any missing or ineffective fasteners. (Upper - 393.71(j) or Lower - 393.71(k))
- (2) Loose mountings. (Upper - 393.71(j) or Lower - 393.71(k))
- (3) Any cracks or breaks in a stress or load-bearing member. (Upper - 393.71(j) or Lower - 393.71(k))
- (4) Horizontal movement between upper and lower saddle-mount halves exceeds 1/4 inch (6.4 mm). (Upper - 393.71(j) or Lower - 393.71(k))

i. Full Trailer (Double Ring, Ball-Bearing Turntable)

- (1) Mounting – Top and Bottom
 - (a) Top flange has less than 6 effective bolts. (393.70(c))
 - (b) Bottom flange has less than 6 effective bolts. (393.70(c))
 - (c) Twenty percent or more of original welds (or repaired original welds), or parent metal cracked. (393.70(c))
- (2) Wear
 - (a) Upper flange half touching lower flange half. (393.70(c))
 - (b) Cracked flanges. (393.70(c))

***4. DRIVELINE/DRIVESHAFT**

a. Yoke Ends (Including Slip Yoke, Yoke Shaft, Tube Yoke and End Fitting Yoke)

- (1) Any visible crack in a yoke end. (396.3(a)(1))
- (2) Any yoke mounting hardware loose (with hand pressure only), broken or missing. (396.3(a)(1))
- (3) Any horizontal or vertical movement of slip joint yoke shaft of greater than 1/2 inch (12.8 mm), with hand pressure only. (396.3(a)(1))

- (4) Any loose, broken or missing end fitting fastener. (Also see item 4.b.(1)) (396.3(a)(1))



Slip Joint



Yoke

Yoke Nut
(mounting hardware)

End Fitting

*b. Universal Joint

- (1) Any independent vertical movement between opposing yoke ends greater than 1/8 inch (3.2 mm), with hand pressure only. (396.3(a)(1))
- (2) Any missing universal joint bearing cap. (Also see item 4.b.(1)) (396.3(a)(1))
- (3) Any missing, broken or loose (with hand pressure only) universal joint bearing cap bolt. (396.3(a)(1))
- * (4) Any bearing cap retainer clip is missing. (396.3(a)(1))

Bearing Cap Retainer Clip



Bearing Assembly Cap

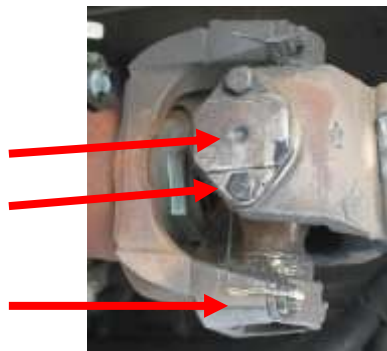

c. Center Bearing (Carrier Bearing)

- (1) Any broken or loose center bearing bracket, bracket bolts or mounting hardware. (396.3(a)(1))
- (2) Any center bearing bracket crack equaling 50 percent or more of the original bracket width. (396.3(a)(1))
- (3) More than 1/2 inch (12.8 mm) vertical movement (with hand pressure only) of the shaft in the center bearing carrier. (396.3(a)(1))

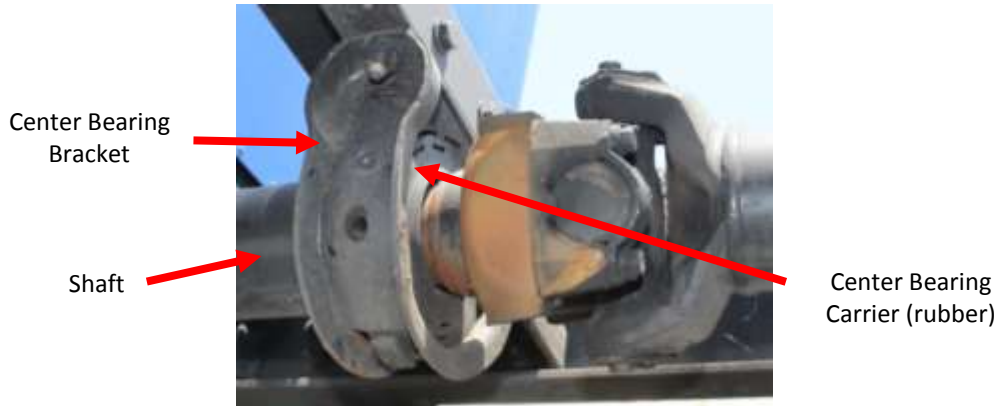

d. Driveshaft Tube

- (1) Any original metal crack in the shaft tube greater than 1/4 inch (6.4 mm) in length. (396.3(a)(1))
- (2) Obvious cracked weld at shaft tube end. (396.3(a)(1))
- (3) Any shaft tube with obvious twist. (396.3(a)(1))

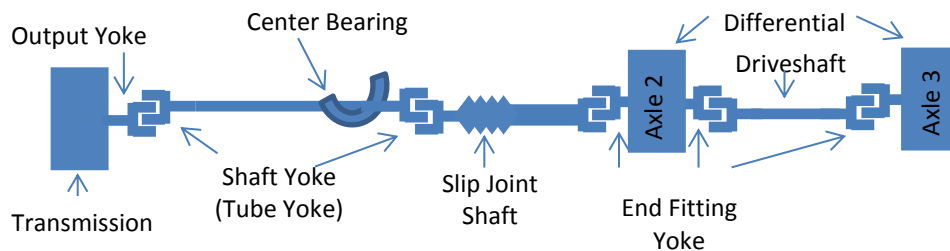

Inspection Bulletin 2014-01 – Driveline/Driveshaft Inspections

5. EXHAUST SYSTEMS

- a. Any exhaust system leaking at a point forward of or directly below the driver/sleeper compartment and the vehicle has a condition that permits entry of exhaust fumes into the driver/sleeper compartment. (393.83(g))
- b. Any bus exhaust system leaking or discharging under the chassis more than 6 inches (15.24 cm) forward of the rear most part of the bus when powered by a gasoline engine, or more than 15 inches (38.1 cm) forward of the rear most part of the bus when powered by other than a gasoline engine, unless the exhaust discharges to the rear of all doors or windows designed to be opened, which

does not include doors or windows designed to be opened solely as emergency exits. (393.83(d))

- c. No part of the exhaust system of any motor vehicle shall be so located as to be likely to result in burning, charring, or damaging the electrical wiring, the fuel supply, or any combustible part of the motor vehicle. (393.83(a))

Inspection Bulletin 2010-02 – Inspection of Vehicles Equipped with 2007 & 2010 EPA Certified Engines

6. FRAMES

a. Frame Members

- (1) Any cracked, loose, sagging, or broken frame siderail permitting shifting of the body onto moving parts or other condition indicating an imminent collapse of the frame. (393.201(a))
- (2) Any cracked, loose, or broken frame member adversely affecting support of functional components such as steering gear, fifth wheel, engine, transmission, body parts and suspension. (393.201(a))
- (3) One and one-half inches (38 mm) or longer crack in frame siderail web which is directed toward bottom flange. (393.201(a))
- (4) Any crack extending from the frame siderail web around the radius and into the bottom flange. (393.201(a))
- (5) One inch (25 mm) or longer crack in siderail bottom flange. (393.201(a))

NOTE: Items (1) and (2) above, apply to all buses, including those having unitized (monocoque) construction. Items (3) and (4) apply only to buses having a body-on-chassis design, such as most school buses.

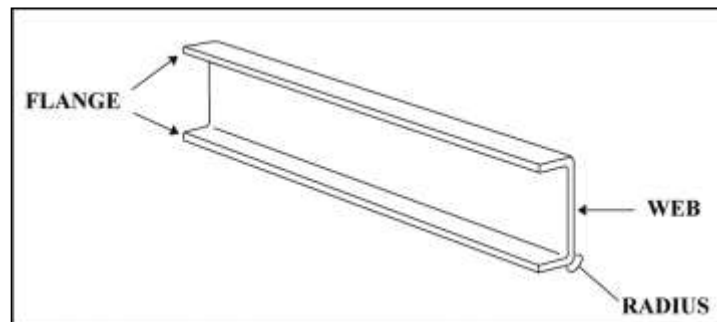

b. Tire and Wheel Clearance

Any condition, including loading that causes the body or frame to be in contact with a tire or any part of the wheel assemblies, at the time of inspection. (396.3(a)(1))

***7. FUEL SYSTEMS**

a. Liquid Fuels

(1) A fuel system with a dripping leak at any point (including refrigeration or heater fuel systems). (396.3(a)(1))

(2) A fuel tank not securely attached to the vehicle. (393.65(c))

NOTE: Some fuel tanks use spring or rubber bushings to permit movement.

(3) Passenger Carrying Vehicle: Missing fuel cap. (393.67(c)(7)(v))

*b. Gaseous Fuels

Compressed Natural Gas (CNG), Liquefied Petroleum Gas (LPG) and Liquefied Natural Gas (LNG)

OCCUPATIONAL SAFETY NOTE: Personnel must exercise extreme caution whenever checking a gaseous fuel system for leaks. Any possibility of creating sparks, static electricity, friction, etc. must be avoided, as they could cause a fire or explosion.

OCCUPATIONAL SAFETY NOTE: Vehicles with leaking gaseous fuel systems must be parked carefully. Gases escaping from CNG and LNG systems will rise. If the vehicle is parked inside a building or under a canopy, roof or similar cover, combustible gasses can collect beneath the ceiling. Escaping LPG falls and can form a “pool” of combustible gas near the ground and displaces air including oxygen. LPG and liquid LNG will flow into open drains. Combustible gases can explode when ignited by an open flame or spark.

*(1) CNG or LPG

Any fuel leakage from the CNG or LPG system detected visibly, audibly or by smell and verified by either a bubble test using non ammonia, non-corrosive soap solution or a reading of more than 5000 PPM on a flammable gas detection meter. (396.3(a)(1))

NOTE: Verification is needed to ensure that the sound is not either internal to the fuel system (such as gas flowing in a pressure regulator, or pressure equalizing between manifolded tanks) or a leak in the air brake system.

NOTE: Some brief fuel leakage or decompression may occur during refueling, causing temporary frosting of CNG or LPG fuel system parts. If the vehicle has been refueled shortly before inspection, care must be taken to distinguish these temporary frosting occurrences from actual leaks.

*(2) LNG

OCCUPATIONAL SAFETY NOTE: LNG is a cryogenic material and presents a potential safety hazard due both to the extremely cold temperature of its liquid and the flammability of its vapor. Personnel inspecting such systems should exercise utmost caution including the wearing of proper eye protection, gloves and clothing.

NOTE: LNG liquid and vaporized gas is odorless and undetectable by the human sense of smell. Frost buildup is not necessarily evidence of leakage. Many components of LNG fuel systems are extremely cold and will exhibit an even coat of frost produced by moisture in the surrounding air condensing and freezing on them.

(a) A cloud of water vapor coming from any component of the fuel system. (396.3(a)(1))

NOTE: It is normal, particularly in humid conditions, for water vapor to collect around many portions of a LNG fuel system.

*(b) Any fuel leakage from the LNG system detected visibly or audibly and verified by either a bubble test using non-ammonia, non-corrosive soap solution or a reading of more than 5000 PPM on a flammable gas detection meter. (396.3(a)(1))

(c) Dripping liquid that boils or vaporizes in the air. (396.3(a)(1))

*8. **LIGHTING DEVICES (HEADLAMPS, TAIL LAMPS, STOP LAMPS, TURN SIGNALS AND LAMPS/FLAGS ON PROJECTING LOADS)**

a. When Lights Are Required

- (1) Headlamps - The single vehicle or towing vehicle does not have at least one head lamp operative on low beam. (Inoperative - 393.9(a); Obscured - 393.9(b); Missing - 393.11(a)(1); or, Driveaway - 393.17(a)(1))
- (2) Lamps on rear - Bus, truck, truck tractor, and towed vehicle (including driveaway/towaway operations) not having at least one steady burning tail lamp on the rear of the rearmost vehicle visible from 500 feet (152.4 m). (Inoperative - 393.9(a); Obscured - 393.9(b); Missing - 393.11(a)(1); or, Driveaway - 393.17(b)(2))
- (3) Lamps on projecting loads - There is not at least one operative steady burning lamp on the rear of loads projecting more than four feet beyond the vehicle body, visible from 500 feet (152.4 m). (Inoperative - 393.9(a); Obscured - 393.9(b); or, Missing - 393.11(a)(1))

*b. At Anytime – Day or Night

- (1) Does not have at least one operative stop lamp on the rear of a single unit vehicle or the rear of the rearmost vehicle of a combination of

vehicles visible at 500 feet (152.4 m). (Inoperative - 393.9(a); Obscured - 393.9(b); Missing - 393.11(a)(1); or, Driveaway - 393.17(b)(2))

- (2) Does not have an operative turn signal visible on each side of the rear of a single unit vehicle or the rear of the rearmost vehicle of a combination of vehicles. (Inoperative - 393.9(a); Obscured - 393.9(b); Missing - 393.11(a)(1); or, Driveaway - 393.17(b)(2))

EXCEPTION: A truck tractor operated as a single unit is not in an out-of-service condition for an inoperative rear turn signal when the turn signals located on the front are visible from the rear.

- (3) Does not have at least one required flag on the rear of loads projecting more than four feet beyond the vehicle body. (393.87(a))
- * (4) All electrical systems on towed vehicle(s) inoperative due to no electrical connection (i.e., unplugged or loose pigtail). (393.23)

NOTE: After electrical connection is re-established, all towed vehicle(s) electrical systems shall be inspected and, if applicable, recorded as per Operational Policy 14.

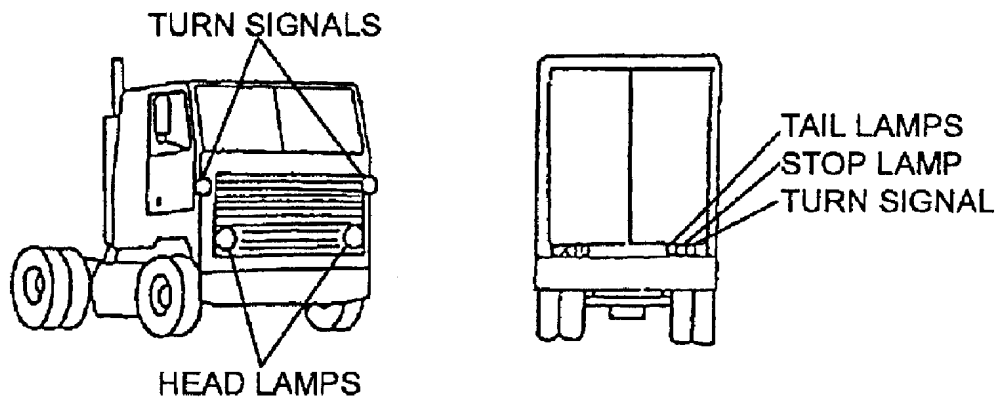

Operational Policy 15 – Inspection/Regulatory Guidance: Regulatory Guidance 8.b.(1) – Clearance Light Violations

Operational Policy 15 – Inspection/Regulatory Guidance: Regulatory Guidance 8.b.(2) – Converter Dolly Lighting

Operational Policy 15 – Inspection/Regulatory Guidance: Regulatory Guidance 8.b.(3) – Retro-Reflective Sheeting

***9. STEERING MECHANISMS**

- a. Steering Wheel Lash (Free Play)

(See Chart: When any of these values - inch movement or degrees - are met or exceeded, vehicle shall be declared out-of-service.) (393.209(b))

For power steering systems, engine must be running.

<u>Steering Wheel Diameter</u>	<u>Manual System Movement 30°</u>	<u>Power System Movement 45°</u>
16" (40.6 cm)	4-1/2" (11.4 cm)(or more)	6-3/4" (17.1 cm)(or more)
18" (45.7 cm)	4-3/4" (12 cm)(or more)	7-1/8" (18.1 cm)(or more)
19" (48.2 cm)	5" (12.7 cm)(or more)	7-1/2" (19 cm)(or more)
20" (50.8 cm)	5-1/4" (13.3 cm)(or more)	7-7/8" (20 cm)(or more)
21" (53.3 cm)	5-1/2" (13.9 cm)(or more)	8-1/4" (20.9 cm)(or more)
22" (55.8 cm)	5-3/4" (14.6 cm)(or more)	8-5/8" (21.9 cm)(or more)

For power systems, if steering wheel movement exceeds 45 degrees before steering axle tires move, proceed as follows: Rock steering wheel left to right between points of power steering valve resistance. If that motion exceeds 30 degrees (or the inch movement values shown for manual steering) vehicle shall be declared out-of-service. This test is to differentiate between excessive lash and power systems designed to avoid providing steering assistance when the steering wheel is turned while the truck is motionless (not moving forward or backward).

b. Steering Column

- (1) Any absence or looseness of u-bolt(s) or positioning part(s). (393.209(c))
- (2) Obviously repair-welded universal joint(s). (393.209(d))
- (3) Steering wheel not properly secured. (393.209(a))
- (4) Telescopic steering column does not lock into position. (396.3(a)(1))
- (5) Tilt steering column does not lock in at least one position. (396.3(a)(1))

c. Front Axle Beam and All Steering Components other than Steering Column (Including Hub)

- (1) Any crack(s). (396.3(a)(1))
- (2) Any obvious welded repair(s). (396.3(a)(1))

d. Steering Gear Box (Including Rack and Pinion)

- (1) Any mounting bolt(s) loose or missing. (393.209(d))
- (2) Any crack(s) in gear box or mounting brackets. (393.209(d))
- (3) Any obvious welded repair(s). (396.3(a)(1))
- (4) Any looseness of the yoke-coupling to the steering gear input shaft. (393.209(d))

Inspection Bulletin 2010-03 – Rack and Pinion Steering System Inspection

e. Pitman Arm

- (1) Any looseness of the pitman arm on the steering gear output shaft. (393.209(d))
- (2) Any obvious welded repair(s). (396.3(a)(1))

*f. Power Steering

Auxiliary power assist cylinder separated at either end from the attachment point(s) allowing movement of more than one inch (25.4 mm) in any direction. (393.209(e))

g. Ball and Socket Joints

- (1) Any movement under steering load of a stud nut. (393.209(d))
- (2) Any motion, other than rotational, between any linkage member and its attachment point of more than 1/8 inch (3.2 mm) measured with hand pressure only. (393.209(d))

Operational Policy 15 – Inspection/Regulatory Guidance: Regulatory Guidance 9.b.(1) – Ball and Socket Violations

- (3) Any obvious welded repair(s). (393.209(d))

h. Tie Rods and Drag Links

- (1) Loose clamp(s) or clamp bolt(s) on tie rods or drag links. (396.3(a)(1))
- (2) Any looseness in any threaded joint. (396.3(a)(1))

i. Nuts

Loose or missing on tie rods, pitman arm, drag link, steering arm, or tie rod arm. (396.3(a)(1))

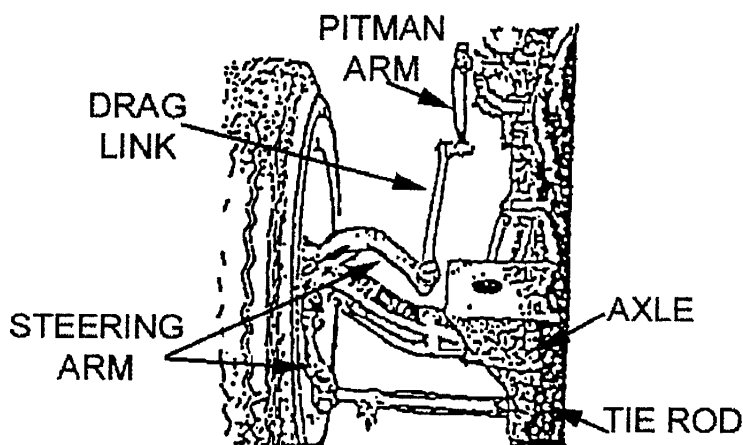

j. Steering System

Any modification or other condition that interferes with free movement of any steering component. (393.209(d))

k. C-Dolly

(1) Missing or inoperable steering locks. (396.3(a)(1))

(2) Steering not centered in the “zero” locked position. (396.3(a)(1))

***10. SUSPENSIONS**

a. Axle Parts/Members

(1) Any u-bolt(s) or other spring to axle clamp bolt(s) cracked, broken, loose, or missing. (393.207(a))

***Operational Policy 15 – Inspection/Regulatory Guidance: OOS
Frequently Asked Questions 10.a.(1) – Spring Eye U-Bolt***

(2) Any axle, axle housing, spring hanger(s), or other axle positioning part(s) cracked, broken, loose, or missing resulting in shifting of an axle from its normal position. (393.207(a))

NOTE: After a turn, lateral axle displacement is normal with some suspensions including composite springs mounted on steering axles.

***Operational Policy 15 – Inspection/Regulatory Guidance: OOS
Frequently Asked Questions 10.a.(2) – Rebound Bolts***

*b. Spring Assembly

(1) One-fourth or more of the leaves in any spring assembly broken. (393.207(c))

(2) Any leaf or portion of any leaf in any spring assembly is missing or separated. (393.207(c))

(3) Any broken main leaf in a leaf spring. (393.207(c))

***Operational Policy 15 – Inspection/Regulatory Guidance: OOS
Frequently Asked Questions 10.a.(3) – Cross Tube Brace***

NOTES:

1. Any leaf of leaf spring assembly is a main leaf if it extends, at both ends, to or beyond:

a. The load bearing surface of a spring hanger or equalizer.

- b. The spring end cap or insulator box mounted on the axle.
 - c. A spring eye, further: Any leaf or a helper spring assembly is a helper main leaf if it extends, at both ends, to or beyond the load bearing surface of its contact pad, hanger, or equalizer.
2. The suspension connecting leaf, in springs having such a leaf, has the same function as the suspension connecting rod components referenced in "Suspension Connecting Rod, Tracking Component Assembly or Sway Bar Components" and should be treated as such a component for purposes of out-of-service.

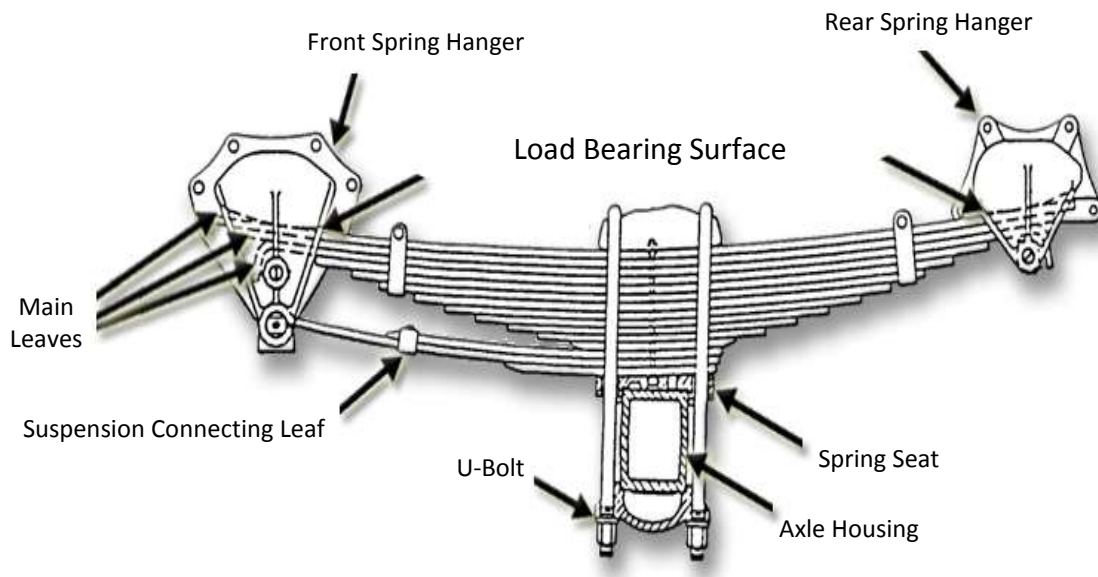

- (4) Coil spring broken. (393.207(d))
- (5) Rubber spring missing. (393.207(a))
- (6) One or more leaves displaced in a manner that could result in contact with a tire, rim, brake drum, or frame. (393.207(c))
- (7) Broken torsion bar spring in torsion bar suspension. (393.207(e))
- * (8) Air Suspension
 - * (a) Deflated air suspension (one or more deflated air spring/bag). (393.207(f))

NOTE: Deflated aftermarket/secondary air bag suspension in addition to a primary leaf/coil spring suspension does not result in an out-of-service condition.

**Operational Policy 15 – Inspection/Regulatory Guidance: OOS
Frequently Asked Questions 10.a.(4) – Aftermarket/Secondary
Air Bags**

- (b) Air spring/bag is missing or is detached at the top or bottom.
(393.207(f))

c. Composite Springs

- (1) Intersecting cracks of any length. (393.207(c))
- (2) A crack that extends beyond 3/4 the length of the spring. (393.207(c))

NOTE: A crack is a separation in any axis which passes completely through the spring.

Intersecting cracks of any length.

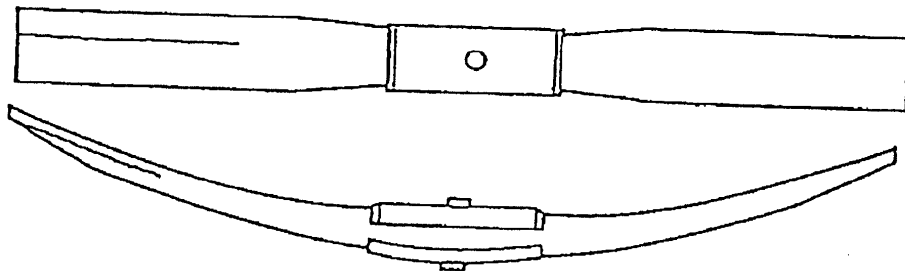

Side to side crack extending beyond 3/4 of the length of the spring. (A crack that extends beyond 3/4 the length of the spring.)

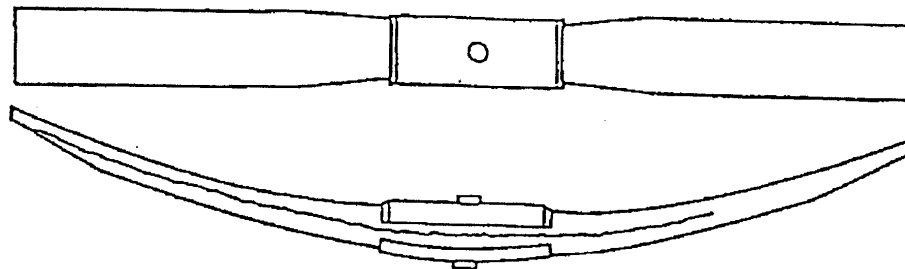

Top to bottom crack extending beyond 3/4 of the length of the spring. (A crack that extends beyond 3/4 the length of the spring.)

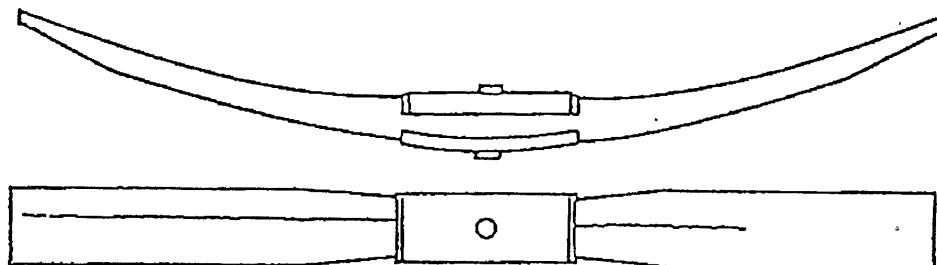

d. Suspension Connecting Rod, Tracking Component Assembly or Sway Bar Components

- (1) Any part of a suspension connecting rod or tracking component assembly (including spring leaves used as a suspension connecting rod) or any part used for attaching same to the vehicle frame or axle that is cracked, loose, broken, or missing. (393.207(a))

Operational Policy 15 – Inspection/Regulatory Guidance: OOS Frequently Asked Questions 10.a.(2) – Rebound Bolts

Operational Policy 15 – Inspection/Regulatory Guidance: OOS Frequently Asked Questions 10.a.(3) – Cross Tube Brace

- (2) Any part of a suspension connecting rod or tracking component assembly (including spring leaves used as a suspension connecting rod) equipped with rubber bushings is missing the bushing or the bushing is worn to the extent that the component can be moved by hand along the axis of the component. (393.207(a))

NOTE: A shock absorber is not a suspension connecting rod. A defective shock absorber will not result in an OOS condition.

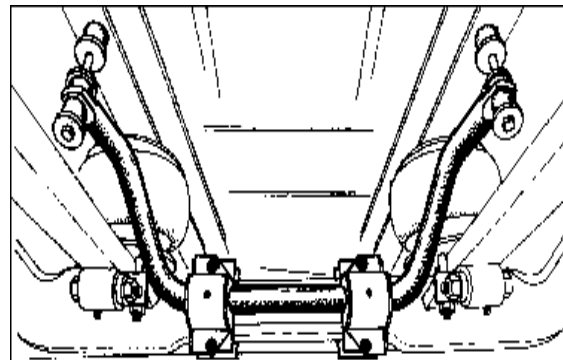
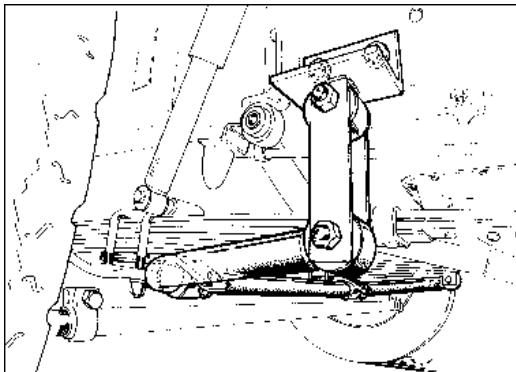
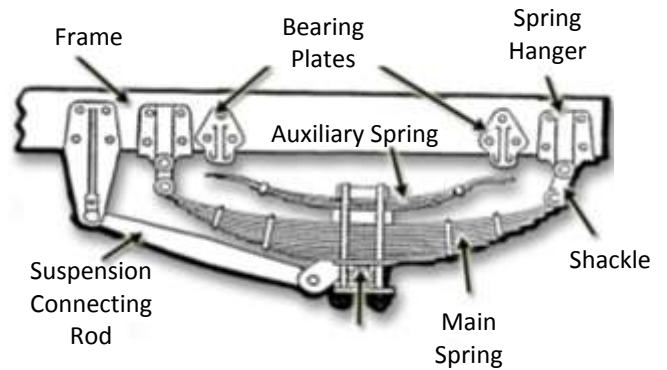
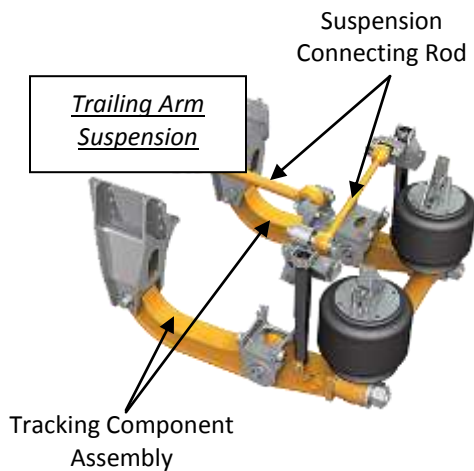

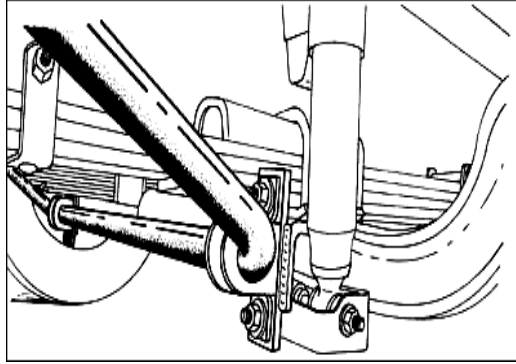

e. Adjustable Axle(s)/Sliding Trailer Suspension System

- (1) More than one-fourth of the locking pins or locking pin holes that are in use meet any of the following conditions:
 - (a) Locking pin is missing or not engaged. (393.207(b))
 - (b) A locking-pin hole measures more than 1 inch (25 mm) larger than its original size. (396.3(a)(1))
 - (c) The material from the hole in use to an adjacent hole, or the material from the hole in use to the edge of the rail, is torn or split. (396.3(a)(1))
- (2) More than one-fourth of the slider-guide/hold-down brackets are missing or disengaged. (396.3(a)(1))
- (3) The sliding suspension attachment member (undercarriage body rail) on either side exhibits a crack of any length in more than 50 percent of its attachment welds. (396.3(a)(1))
- (4) A sliding suspension member's (undercarriage body rail) attachment welds are cracked completely through along a 4 foot (1.2 m) continuous length of the body rail. (396.3(a)(1))
- (5) A sliding suspension attachment member (undercarriage body rail) is cracked completely through along a 4 foot (1.2 m) continuous length. (396.3(a)(1))

***11. TIRES**

a. Any Tire on Any Front Steering Axle(s) of a Power Unit

- (1) With less than 2/32 inch (1.6 mm) tread when measured in any two adjacent major tread grooves (typically any groove containing a tread wear indicator) at any location on the tire. (393.75(b))

NOTE: Measurements should not be made on stone ejectors or tread wear indicators.

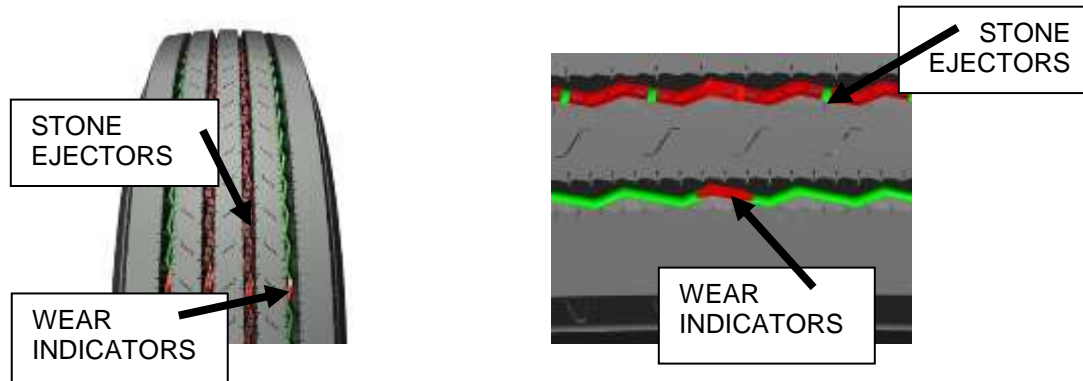

**Operational Policy 15 – Inspection/Regulatory Guidance: OOS
Frequently Asked Questions 11.a.(1) – Major Tread Groove**

- (2) When any part of the belt material, breaker strip or casing ply is showing in the tread. (393.75(a)(1))
- (3) When sidewall is cut, worn, or damaged to the extent that the steel or fabric ply cord is exposed. (393.75(a)(1))
- (4) Labeled “Not For Highway Use” or carrying other markings that indicate excluded use on steering axles. (396.3(a)(1))
- (5) Visually observable bump, bulge, or knot apparently related to tread or sidewall separation. (393.75(a)(2))

EXCEPTION: A bulge (due to a repair) of up to 3/8 inch (9.5 mm) in height is allowed. This bulge may sometimes be identified by a blue triangular label in the immediate vicinity.

- (6) Presence of rubber coated cord or cured rubber plug in the sidewall. (396.3(a)(1))
- (7) Tire has noticeable (e.g., can be heard or felt) leak, or has fifty (50) percent or less of the maximum inflation pressure marked on the tire sidewall. (393.75(a)(3))

NOTE: Measure tire air pressure only if there is evidence the tire is under-inflated.

**Operational Policy 15 – Inspection/Regulatory Guidance: Regulatory
Guidance 11.b.(1) – Tire Inflation Pressure**

- (8) So mounted or inflated that it comes in contact with any part of the vehicle. (396.3(a)(1))

NOTE: An out-of-service condition exists only if the tire can be made to contact another component at the time of inspection.

- (9) Weight carried exceeds tire load limit. This includes overloaded tire resulting from low air pressure. (Load Limit - 393.75(f) or Inflation Pressure - 393.75(h))

EXCEPTION: Does not apply to vehicles being operated under the special permit exclusion. (393.75(f)(1) or 393.75(f)(2))

- (10) Passenger Carrying Vehicle: Regrooved, recapped, or retreaded tires on front steering axles. (393.75(d))

b. All Tires Other Than Those Found on the Front Steering Axle(s) of a Powered Unit

- (1) Tire has noticeable (e.g., can be heard or felt) leak, or has fifty (50) percent or less of the maximum inflation pressure marked on the tire sidewall. (393.75(a)(3))

NOTE: Measure tire air pressure only if there is evidence the tire is under-inflated.

- (2) Any tire with visually observable bump or knot apparently related to tread or sidewall separation. (393.75(a)(2))

EXCEPTION: A bulge (due to a repair) of up to 3/8 inch (9.5 mm) in height is allowed. The bulge may sometimes be identified by a blue triangular label in the immediate vicinity.

- (3) So mounted or inflated that it comes in contact with any part of the vehicle. (396.3(a)(1))

NOTE: This includes any tire contacting its mate in a dual set.

- (4) Weight carried exceeds tire load limit. This includes overloaded tire resulting from low air pressure. (Load Limit - 393.75(f); 393.75(g)(1); 393.75(g)(2); or, Inflation Pressure - 393.75(h))

EXCEPTION: Does not apply to vehicles being operated under the special permit exclusion. (393.75 (f)(1) or 393.75(f)(2))

- (5) Seventy-five (75) percent or more of the tread width loose or missing in excess of 12 inches (30.4 cm) in circumference. (393.75(a)(2))

- (6) Bias Ply Tire: When more than one ply is exposed in the sidewall and the area exceeds 2 square inches (12.9 sq cm). (393.75(a)(1))

- (7) Radial Ply Tire: When more than one ply is exposed in the sidewall and the area exceeds 2 square inches (12.9 sq cm). (393.75(a)(1))

The following conditions apply to all tires; however, when these conditions are found on a dual tire set, both tires must meet one or more of the conditions listed in item 11.b.

- (8) Bias Ply Tire: When more than one ply is exposed in the tread area and the exposed area of the top ply exceeds 2 square inches (12.9 sq cm) or damaged plies are evident in the sidewall up to 2 square inches (12.9 sq cm). (393.75(a)(1))
- (9) Radial Ply Tire: When two or more plies are exposed in the tread area and the exposed area of the top ply exceeds 2 square inches (12.9 sq cm) or damaged cords are evident in the sidewall up to 2 square inches (12.9 sq cm). (393.75(a)(1))
- (10) Presence of rubber coated cord or cured rubber plug in the sidewall. (396.3(a)(1))
- (11) So worn that less than 1/32 inch (.8 mm) tread remains when measured in any two adjacent major tread grooves (typically any groove containing a tread wear indicator) at 3 separate locations around the circumference of the tire at least 8 inches apart. (393.75(c))

NOTE: Measurements should not be made on stone ejectors or tread wear indicators.

Operational Policy 15 – Inspection/Regulatory Guidance: OOS Frequently Asked Questions 13.a.(1) – Removing a Wheel/Chaining Up an Axle

*c. Lodged Items Between Tires of a Dual Tire Set

- *(1) Any solid item lodged between a set of dual tires that is in direct contact with the sidewalls of the tires (excluding mud and snow). (396.7(a))

12. VAN AND OPEN-TOP TRAILER BODIES

a. Upper Rail

- (1) Broken with complete separation of the flange. (393.201(a))
- (2) Buckled or cracked when accompanied by missing, working (movement under stress) or loose fasteners at adjacent roof bows and/or side posts. (393.201(a))
- (3) Buckled or cracked when accompanied by broken, ineffective, or missing adjacent roof bows. (393.201(a))

b. Lower Rail

- (1) Broken with complete separation in the bay area accompanied by sagging floor, rail, or crossmember; or broken with loose, working (movement under stress) or missing fasteners at side posts adjacent to the crack. (393.201(a))

NOTE: The lower rail of a van or open-top trailer can become gouged, chunked, or bent during operation. These are superficial damages only and do little to degrade the rail's strength or integrity.

- (2) Drop frame trailers showing twists, bends, or fatigue cracking at the drop frame's elevation changes. (393.201(a))

c. Floor Crossmembers

- (1) Three or more adjacent broken, and/or completely detached from and sagging below the lower rail in the bay area. (393.201(a))
- (2) Broken floor accompanied by protruding freight and sagging crossmembers. (393.201(a))

d. Side Panels on Fiberglass Reinforced Plywood (FRP) Trailers

Damage in the bay area that penetrates completely through the fiberglass and plywood resulting in a sagging lower rail. (393.201)

NOTES: The following apply to all items under "Van and Open-Top Trailer Bodies".

1. These conditions are only considered out-of-service if the failure is in the bay area (aft of kingpin coupler plate and forward of the axle sub frame rails).
2. Trailers 30 feet (9.14 m) or less in length have a short bay area and are not as susceptible to catastrophic failures, therefore, only rail breaks accompanied by a sagging floor, rail, or crossmember are out of service for them.
3. Rail, post, bow, crossmember, and side/front panel damage in areas outside the bay area are not imminently hazardous and should not be considered out-of-service unless they lead to conditions described in other items of the *North American Standard Out-of-Service Criteria*.

13. WHEELS, RIMS AND HUBS

a. Lock or Side Ring

Bent, broken, cracked, improperly seated, sprung, or mismatched ring(s). (393.205(a))

b. Rim Cracks

Any circumferential crack. (393.205(a))

c. Disc Wheel Cracks

- (1) Any crack exceeding 3 inches (76.2 mm) in length. (393.205(a))
- (2) A crack extending between any two holes (hand holes, stud holes and center holes). (393.205(a))
- (3) Two or more cracks anywhere on the wheel. (393.205(a))

d. Bolt/Stud Holes (Disc Wheels)

Any visible elongated bolt/stud hole. (393.205(b))

e. Spoke Wheel Cracks

(1) Two or more cracks more than 1 inch (25.4 mm) long across a spoke or hub section. (393.205(a))

(2) Two or more web areas with cracks. (393.205(a))

f. Tubeless Demountable Adapter Cracks

(1) A crack exceeding 3 inches (76.2 mm). (393.205(a))

(2) Cracks at three or more spokes. (393.205(a))

g. Wheel Fasteners

Loose, missing, broken, cracked, or stripped wheel fasteners that are ineffective as follows: for 10 fastener positions - 3 anywhere or 2 adjacent; for 8 fastener positions or less - 2 anywhere (this applies to both spoke and disc wheels). (393.205(c))

h. Welds

(1) Any cracks in welds attaching disc wheel to rim. (393.205(a))

(2) Any crack in welds attaching tubeless demountable rim to adapter. (393.205(a))

(3) Any welded repair on any aluminum wheel(s). (396.3(a)(1))

(4) Any welded repair other than disc to rim attachment on steel disc wheel(s). (396.3(a)(1))

i. Hubs

(1) When any bearing (hub) cap, plug or filler plug is missing or broken allowing an open view into hub assembly. (396.3(a)(1))

(2) Smoking from wheel hub assembly due to bearing failure. (396.3(a)(1))

NOTE: Refer to "Brake Systems – Brake Smoke/Fire"; as the cause may either be the brakes or a problem in the hub and bearing area.

(3) When any wheel seal is leaking. This must include evidence of wet contamination of the brake friction material and accompanied by evidence that further leaking will occur. (396.5(b))

NOTE: Refer to the applicable contaminated friction material criterion in "Brake Systems", when condition is present.

NOTE: Grease/oil on the brake lining edge, back of shoe, or drum edge and oil stain with no evidence of fresh oil leakage are not conditions for out-of-service.

- (4) Lubricant is leaking from the hub and is present on the wheel surface (caused by a loose hub cap or hub cap bolts, or hub cap damage) accompanied by evidence that further leakage will occur. (396.5(b))
- (5) No visible or measurable amount of lubricant showing in hub. (396.5(a))

Operational Policy 15 – Inspection/Regulatory Guidance: OOS Frequently Asked Questions 13.a.(1) – Removing a Wheel/Chaining Up an Axle

14. WINDSHIELD WIPERS

Any power unit that has an inoperative wiper or missing, or damaged parts that render it ineffective on the driver's side. (Applicable only in inclement weather requiring use of windshield wipers.) (393.78(a) or 393.78(b))

15. BUSES, MOTOR COACHES, PASSENGER VANS OR OTHER PASSENGER CARRYING VEHICLES – EMERGENCY EXITS/ELECTRICAL CABLES AND SYSTEMS IN ENGINE AND BATTERY COMPARTMENTS/SEATING

a. Emergency Exits

Required and/or marked emergency exits that are missing, inoperative (does not open, close, and/or secure as designed), or obstructed. (393.62)

b. Electrical Cables and Systems in Engine and Battery Compartments

- (1) Electrical cable insulation chafed, frayed, damaged, burnt, causing bare cable to be exposed. (393.28)
- (2) Missing or damaged protective grommets insulating electrical cables through metal compartment panels. (393.28)
- (3) Broken or unsecured mounting of electrical components. (396.3(a)(1))
- (4) Electrical cables unsupported, hanging or missing clamps that may cause a chafing or frayed condition. (393.28)
- (5) Any visual leaking of lubricant (i.e., engine supplied oil pressure) from electrical component such as alternator, auxiliary heater, etc. (396.5(b))

NOTE: A cable is the power-conveying part of a high wattage/voltage electrical system. It usually has no circuit overload protection included in the system (i.e., battery to electrical starter or alternator to battery).

c. Loose and/or Temporary Seating

- (1) No bus, motor coach, passenger van or other passenger carrying vehicle:

- (a) Shall be equipped with aisle seats unless such seats are so designed and installed as to automatically fold and leave a clear aisle when they are unoccupied. (393.91)
- (b) Shall be operated if any temporary seating, occupied or not, therein is not secured to the vehicle in a workmanlike manner. This includes the use of items not designed for use as seats in vehicles, including but not limited to, milk crates, folding chairs, plastic steps, or plastic stools. (393.91)
- (c) Shall be operated with the presence of any seating, whether secured or unsecured, in excess of the manufacturer's (manufacturer, remanufacturer, or final stage manufacturer) designed seating capacity. (390.33)

NOTE: (a), (b) or (c) does not apply to mobility devices (such as wheel chairs) secured in vehicles using proper tiedowns.

Part III

NORTH AMERICAN STANDARD HAZARDOUS MATERIALS OUT-OF-SERVICE CRITERIA

POLICY STATEMENT

The purpose of this part is to provide criteria for the abatement of unsafe conditions in the transportation of hazardous materials/dangerous goods and is based upon the presence of any condition(s) which fail(s) to communicate the hazard(s) or is an imminent hazard.

Except where state, provincial, territorial, or federal laws preclude enforcement of a named item, motor carrier safety enforcement personnel and their jurisdictions shall comply with these out-of-service violation standards.

OUT-OF-SERVICE: Condition(s) categorized in this document as “out-of-service” shall not be allowed to continue in commerce until the out-of-service condition(s) is/are fully corrected and complies with the applicable regulations. If, at the discretion of the inspector, it is less hazardous to the public to relocate the vehicle, it shall be towed, transported, or escorted to a safe location only at the direction of an official authority.

When a vehicle is declared out-of-service for a condition, all violations that contributed to the specific out-of-service condition must be repaired (e.g., a vehicle declared out-of-service for 50 percent or more missing placards must have all missing placards replaced prior to being released).

An out-of-service condition cannot be corrected by creating a new violation (e.g., if a vehicle is declared out-of-service for two missing placards, an otherwise compliant placard cannot be removed from another vehicle in the combination if such removal would create a violation on that other vehicle).

When a U.S. DOT/Transport Canada specification cargo tank inspection is completed in conjunction with North American Standard Level I and/or Level V Inspection CVSA decals shall not be issued to U.S. DOT/Transport Canada specification cargo tank vehicles found to have violations of the following:

- Retest Requirements
- Cargo Tank Authorization
 - Does not include specification shortages
- Manhole Covers
- Internal Valves
- Discharge Valves
- Cargo Tank Integrity
- Supports and Anchoring
- Double Bulkhead Drains
- Ring Stiffeners
- Rear End Protection
- Emergency Flow Control
- Piping and Protection
- Overturn Protection
- Venting

1. **SHIPPING PAPERS – GENERAL**

Present when required. An out-of-service condition exists when transporting HM/DG not accompanied by a shipping paper clearly identifying the specific HM/DG being transported. An error in the shipping description or an incomplete shipping description that will not impede emergency response does not constitute an out-of-service condition.

2. **PLACARDING**

a. The required placards must be displayed on a transport vehicle.

b. Number and Type of Placards:

An out-of-service condition exists when 50 percent or more of the required placards for a hazard class are missing or any placard(s) misrepresent(s) the HM/DG being transported.

NOTE: For this out-of-service item to apply, HM/DG must be present.

3. **BULK PACKAGES**

a. Internal Valve (Missing)

An out-of-service condition exists if the internal valve is missing when required.

b. Internal Valve (Open)

An out-of-service condition exists when the internal valve is in the open position.

c. Bulk Package Authorization

An out-of-service condition exists when transporting HM/DG in a bulk package not authorized for the material being transported. Unless otherwise indicated herein, specification shortages shall not disqualify an otherwise authorized package.

d. Venting Devices, Manhole Covers, Fill / Inspection Openings and Discharge Valves

Missing or improperly secured venting devices, manhole covers, fill/inspection openings or discharge valves constitute an out-of-service condition.

e. Bulk Package Integrity

HM/DG leaking from a bulk package (including associated piping) constitutes an out-of-service condition.

f. Supports and Anchoring

An out-of-service condition exists when more than 25 percent of the supporting and/or anchoring mechanisms are ineffective.

NOTE: A bulk package which is also an intermodal container must also be secured in accordance with “Cargo Securement” in Part II.

4. TRANSPORT VEHICLE MARKINGS

a. The Required ID Numbers Must Be Displayed On A Transport Vehicle:

The ID numbers may be displayed on orange panels, a white square-on-point configuration, or incorporated with the placards.

An out-of-service condition exists when 50 percent or more of the required ID numbers are missing for each material or when any ID number misrepresents the material transported.

NOTE: In Canada required placards and markings must be displayed on four sides of all large means of containment.

NOTE: For this out-of-service item to apply, an HM/DG must be present.

5. POISON INHALATION HAZARD (PIH) MARKINGS

a. Non-Bulk Packaging – Present When Required

An out-of-service condition exists when required markings are missing or illegible.

b. Bulk Packaging – Present When Required

An out-of-service condition exists when required markings are missing or illegible.

6. NON-BULK PACKAGING

Package Integrity

HM/DG leaking in or from a package constitutes an out-of-service condition.

7. LOADING AND SECUREMENT

a. Blocking and Bracing

Transporting HM/DG not blocked, braced, or secured as required by applicable regulation constitutes an out-of-service condition.

NOTE: Any shifting likely to adversely affect HM/DG package integrity, under conditions normally incident to transportation.

b. Product Compatibility

Transporting incompatible commodities constitutes an out-of-service condition, unless otherwise excepted.

c. Poison/Edible Materials

Transporting packages requiring “poison”/“toxic” or “poison – inhalation hazard”/“toxic - inhalation hazard” label(s) in the same vehicle with foodstuffs, feed, or other edible materials intended for consumption by humans or animals constitutes an out-of-service condition, unless otherwise excepted.

NOTE: When initiating an out-of-service action, contact proper health authority within your jurisdiction.

8. **FORBIDDEN ITEMS**

Forbidden Materials

The transportation of forbidden items constitutes an out-of-service condition.

9. **RADIOACTIVE MATERIALS – RADIATION LEVELS**

Measured at Surface of Vehicle

An out-of-service condition exists when measurement exceeds 2mSv/hr (200 mrem/hour), at accessible surface of vehicle.

NOTE: When initiating out-of-service action, contact the appropriate health physicists, or radiation agency with jurisdiction.

10. **EMERGENCY RESPONSE ASSISTANCE PLAN (ERAP)** (In Canada Only)

An out-of-service condition exists when HM/DG are transported in Canada without an approved ERAP when it is required.

Part IV

NORTH AMERICAN STANDARD ADMINISTRATIVE OUT-OF-SERVICE CRITERIA

POLICY STATEMENT

The purpose of this part is to identify violations that prohibit the motor carrier from operating the commercial motor vehicle until the condition is corrected. The violations in this section are important aspects of the carrier's ability to operate lawfully and to help in maintaining uniformity across the industry.

The necessity for all enforcement personnel to implement and adhere to these standards is: (1) a matter of law; (2) perceived as necessary by the society we are charged with protecting, and (3) a professional obligation if substantial enhancement in the safety of commercial motor vehicle operators is to be achieved.

Except where state, provincial, territorial, or federal laws preclude enforcement of a named item, motor carrier safety enforcement personnel and their jurisdictions shall comply with these out-of-service violation standards.

OUT-OF-SERVICE VIOLATION: Violations under this category preclude further operation of a commercial motor vehicle by the carrier for a specified period of time or for some violations until a specific requirement has been complied with.

FMCSR code references in the *North American Standard Out-of-Service Criteria* are simply recommendations to help inspectors find an appropriate citation. Other violation codes may be more suitable for a specific condition.

1. OPERATING AUTHORITY

Operating a motor vehicle without the required operating authority or beyond the scope of the motor carriers' operating authority. (Authority Required - 392.9a(a)(1) or Beyond Scope - 392.9a(a)(2)) **Declare vehicle out-of-service until the proper operating authority is obtained.**

2. MEXICO DOMICILED CARRIERS OPERATING IN THE U.S.

A Mexico-domiciled carrier (USDOT X Number) granted provisional operating authority pursuant to 49 CFR 365 operating a commercial motor vehicle in the United States that does not display a current CVSA decal on the power unit. (385.103(c)) **Declare vehicle out-of-service until the vehicle satisfactorily passes an inspection and a CVSA decal is issued.**

3. U.S. FEDERAL OUT-OF-SERVICE ORDERS

Operating a commercial motor vehicle while an existing motor carrier out of service order, issued by the Federal Motor Carrier Safety Administration (FMCSA) is in effect. (Choose from the list of fourteen Sections of the Federal Motor Carrier Safety Regulations (CFRs) listed below.) **Declare vehicle out-of-service until such time as the motor carrier out-of-service order issued by FMCSA has been satisfied.**

Description	Section
Failure to Pay Fine – Private Carrier	386.83(a)(1)
Failure to Pay Fine – For-Hire Carrier	386.83(a)(1)
UNSAT/UNFIT – Placarded HM	385.13(a)(1)
UNSAT/UNFIT – Passenger Carriers	385.13(a)(1)
UNSAT/UNFIT – Property Carriers	385.13(a)(2)
New Entrant – Failure to Respond to Expedited Action Notification	385.308(d)
New Entrant – Failure of Safety Audit	385.325(c)
New Entrant – Refusal of Audit/No Contact	385.337(b)
Imminent Hazard – Motor Carrier	386.72(b)(4)
Imminent Hazard – Intermodal Equipment Provider	386.72(b)(4)
MX Carrier – Inadequate Corrective Action	385.105(b)
MX Carrier – UNSAT/UNFIT	385.111(a)
MX Carrier – Suspended Operating Authority for UNSAT Rating or Failed Safety Audit	385.111(c)(1)
MX Carrier – Revoked Operating Authority	385.111(c)(2)

Enforcement Guidance: All out-of-service orders must be confirmed. Vehicles shall only be declared out-of-service after online or telephonic verification of the motor carrier's out-of-service order.

Appendix

NORTH AMERICAN STANDARD OUT-OF-SERVICE CRITERIA

POLICY STATEMENT

The information contained/included in this Appendix is provided as a reference and/or guidance on roadside commercial motor vehicle enforcement activities and CVSA decal applicability and application. For more detailed and current information regarding the roadside North American Standard Inspection Program, refer to the Alliance Bylaws, Operational Policy, and/or Inspection Procedures.

North American Standard Inspection Levels

Level I

North American Standard Inspection – An inspection that includes examination of driver's license; medical examiner's certificate and Skill Performance Evaluation (SPE) Certificate (if applicable); alcohol and drugs; driver's record of duty status as required; hours of service; seat belt; vehicle inspection report(s) (if applicable); brake systems; cargo securement; coupling devices; driveline/driveshaft; exhaust systems; frames; fuel systems; lighting devices (headlamps, tail lamps, stop lamps, turn signals and lamps/flags on projecting loads); steering mechanisms; suspensions; tires; van and open-top trailer bodies; wheels, rims and hubs; windshield wipers; buses, motor coaches, passenger vans or other passenger carrying vehicles – emergency exits/electrical cables and systems in engine and battery compartments/seating, and HM/DG requirements as applicable. HM/DG required inspection items will be inspected by certified HM/DG inspectors.

NOTE: If more than 20 percent of pushrod travel, on exposed pushrods, cannot be measured, then the inspection would not be considered a Level I inspection and shall be identified as a Level II inspection.

NOTE: A 5-axle vehicle combination with one axle not measured will still require two defective brakes to be placed out-of-service 20 percent.

Level II

Walk-Around Driver/Vehicle Inspection – An examination that includes each of the items specified under the North American Standard Level II Walk-Around Driver/Vehicle Inspection Procedure. As a minimum, Level II inspections must include examination of: driver's license; medical examiner's certificate and Skill Performance Evaluation (SPE) Certificate (if applicable); alcohol and drugs; driver's record of duty status as required; hours of service; seat belt; vehicle inspection report(s) (if applicable); brake systems; cargo securement; coupling devices; driveline/driveshaft; exhaust systems; frames; fuel systems; lighting devices (headlamps, tail lamps, stop lamps, turn signals and lamps/flags on projecting loads); steering mechanisms; suspensions; tires; van and open-top trailer bodies; wheels, rims and hubs; windshield wipers; buses, motor coaches, passenger vans or other passenger carrying vehicles – emergency exits/electrical cables and systems in engine and battery compartments/seating, and HM/DG requirements as applicable. HM/DG required inspection items will be inspected by certified HM/DG inspectors. It is contemplated that the walk-around driver/vehicle inspection will include only those items, which can be inspected without physically getting under the vehicle.

Level III

Driver/Credential Inspection – An examination that includes those items specified under the North American Standard Level III Driver/Credential Inspection Procedure. As a minimum, Level III inspections must include, where required and/or applicable, examination of the driver's license; medical examiner's certificate and Skill Performance Evaluation (SPE) Certificate; driver's record of duty status; hours of service; seat belt; vehicle inspection report; and HM/DG requirements. Those items not indicated in the North American Standard Level III Driver/Credential Inspection Procedure shall not be included on a Level III inspection.

Level IV

Special Inspections – Inspections under this heading typically include a one-time examination of a particular item. These examinations are normally made in support of a study or to verify or refute a suspected trend.

Level V

Vehicle-Only Inspection – An inspection that includes each of the vehicle inspection items specified under the North American Standard Inspection (Level I), without a driver present, conducted at any location.

Level VI

North American Standard Inspection for Transuranic Waste and Highway Route Controlled Quantities (HRCQ) of Radioactive Material – An inspection for select radiological shipments, which include inspection procedures, enhancements to the North American Standard Level I Inspection, radiological requirements, and the *North American Standard Out-of-Service Criteria for Transuranic Waste and Highway Route Controlled Quantities (HRCQ) of Radioactive Material*.

As of January 1, 2005, all vehicles and carriers transporting highway route controlled quantities (HRCQ) of radioactive material are regulated by the U.S. Department of Transportation and required to pass the North American Standard Level VI Inspection.

Previously, U.S. Department of Energy (DOE) voluntarily complied with the North American Standard Level VI Inspection Program requirements.

Select radiological shipments include highway route controlled quantities (HRCQ) of radioactive material as defined by Title 49 CFR Section 173.403. And, because only a small fraction of transuranics are HRCQ, DOE has decided to include its transuranic waste shipments in the North American Standard Level VI Inspection Program.

Level VII

Jurisdictional Mandated Commercial Vehicle Inspection – An inspection that is a jurisdictional mandated inspection program that does not meet the requirements of any other level of inspection. An example will include inspection programs such as, but not limited to: school buses; limousines; taxis; shared ride; hotel courtesy shuttles, and other intrastate/intraprovincial operations. These inspections may be conducted by CVSA-certified inspectors, other designated government employees or jurisdiction approved contractors. Inspector training requirements shall be determined by each jurisdiction. No CVSA decal shall be issued for a Level VII inspection but a jurisdiction-specific decal may be applied.

Qualifying for CVSA Decals

General

The North American Standard Level I and/or Level V are the only inspections that may result in issuance of a CVSA decal. To qualify for a CVSA decal, a vehicle must not have any Critical Vehicle Inspection Item violations contained in CVSA Operational Policy.

Inspections must be performed by and CVSA decals affixed by North American Standard Level I and/or Level V certified inspectors. The term “certified” as used in this section means the government employee performing inspections and/or affixing CVSA decals must have first successfully completed a training program approved by the Alliance. CVSA decals, when affixed, shall remain valid for a period not to exceed three consecutive months. Vehicles displaying a valid CVSA decal generally will not be subject to re-inspection.

However, nothing shall prevent re-inspection of a vehicle or combination of vehicles bearing valid CVSA decals, under the conditions specified in the section titled, “Vehicle Re-Inspections”.

Critical Vehicle Inspection Items

- Brake Systems
- Cargo Securement
- Coupling Devices
- Driveline/Driveshaft
- Exhaust Systems
- Frames
- Fuel Systems
- Lighting Devices (Headlamps, Tail Lamps, Stop Lamps, Turn Signals and Lamps/Flags on Projecting Loads)
- Steering Mechanisms
- Suspensions
- Tires
- Van and Open-Top Trailer Bodies
- Wheels, Rims and Hubs
- Windshield Wipers
- Buses, Motor Coaches, Passenger Vans or Other Passenger Carrying Vehicles – Emergency Exits/Electrical Cables and Systems in Engine and Battery Compartments/Seating

Raised Lift Axle(s)

Raised lift axles are to be inspected to ensure all components are secure and for conditions that adversely affect the vehicles operation (i.e., air leaks, etc.). If a Critical Vehicle Inspection Item defect is discovered on the raised axle, the vehicle is not eligible to receive a CVSA decal and the defect should be documented in the notes section of the inspection report. The raised lift axle shall not be included in determining the total number of brakes on a vehicle combination for the 20 percent service brake calculation. If the raised lift axle is required to be lowered to comply with regulatory requirements in order to continue operation, the operator has the option to adjust or offload cargo. Otherwise the axle is subject to inspection.

CVSA Decals on Cargo Tanks

When a U.S. DOT / Transport Canada specification cargo tank inspection is completed in conjunction with North American Standard Level I and/or Level V Inspection CVSA decals shall not be issued to U.S. DOT / Transport Canada specification cargo tank vehicles found to have violations of the following:

- Retest Requirements
- Cargo Tank Authorization
 - Does not include specification shortages
- Manhole Covers
- Internal Valves
- Discharge Valves
- Cargo Tank Integrity
- Supports and Anchoring
- Double Bulkhead Drains
- Ring Stiffeners
- Rear End Protection
- Emergency Flow Control
- Piping and Protection
- Overturn Protection
- Venting

Vehicle Inspections

Each vehicle (i.e., motorcoach, school bus, other bus, truck, truck tractor, semi-trailer, trailer, converter dollies, etc.) used singularly or in combination may qualify for a CVSA decal if it passes inspection, and a CVSA decal shall be applied. "Pass Inspection" means that during a North American Standard Level I or Level V Inspection no defects are found in the Critical Vehicle Inspection Items.

For the purpose of a CVSA decal issuance, if no violation is detected during a North American Standard Level I or Level V Inspection due to a hidden part, other than pushrod stroke measurements, of the listed Critical Vehicle Inspection Items, then a CVSA decal shall be applied. However, if more than 20 percent of pushrod travel, on exposed pushrods, cannot be measured, then a CVSA decal shall not be applied. An inspector can still apply a CVSA decal even though his/her jurisdiction does not allow for the inspection of gaseous fuel systems.

The CVSA decal criteria apply only to the condition of the vehicle, not the driver. It is possible for a driver to be out-of-service and still have vehicle(s) qualify for a CVSA decal.

Vehicle Re-Inspections

A Critical Vehicle Inspection Item violation(s) (OOS or otherwise) noted during a CVSA Level I inspection that is successfully repaired on-site and re-inspected by the same inspector at the same inspection location will qualify for a CVSA decal as long as all previously noted Critical Vehicle Inspection Item violation(s) have been properly repaired. In such instances, only a re-inspection of the repaired violation(s) shall be done with decal(s) being applied to the vehicle(s) and properly noted upon the original inspection.

Any vehicle that is repaired off-site or inspected by a different inspector shall be required to have a complete inspection conducted in order to obtain a CVSA decal.

Nothing within this policy shall require an inspector to re-inspect a vehicle, with that decision being left to the individual inspector and his/her agency.

For the purposes of uniformity in the application of this section and maximum maintenance of the reciprocity standard, re-inspection of a vehicle bearing a current and valid CVSA decal is contemplated under the following circumstances:

1. A North American Standard Critical Vehicle Inspection Items or out-of-service violation is detected;
2. When a North American Standard Level IV (Special Inspection) exercise is involved;
3. When a statistically based random inspection technique is being employed to validate an individual jurisdiction or regional out-of-service percentage; Or,
4. When re-inspections are conducted to maintain CVSA North American Standard Inspection quality assurance.

Required Repairs for Out-of-Service Notices

The following shall be the policy regarding required repairs for out-of-service notices:

No motor carrier shall require nor shall any person operate, or any inspector release any commercial motor vehicle declared "out-of-service" until all repairs required by the "out-of-service notice" have been satisfactorily completed to where a violation no longer exists.

When a vehicle is declared out-of-service for a condition resulting from an accumulation of violations, all violations that contributed to the specific out-of-service condition must be repaired (e.g., a vehicle, or vehicles in combination declared out-of-service for 20 percent defective brake violations must have all the 20 percent defective brake violations repaired prior to being released; or, a vehicle declared out-of-service for two tires at less than 1/32 inch (0.8 mm) tread depth must have both tire violations repaired prior to the vehicle being released, etc.). Once all of the contributing out-of-service violations have been repaired on any vehicle in a combination, that specific vehicle in the combination is no longer considered to be out-of-service.

An out-of-service condition cannot be corrected by creating a new violation (e.g., if a vehicle is declared out-of-service for three missing wheel fasteners on one wheel, wheel fasteners from other wheels cannot be removed to correct this out-of-service condition, etc.).

When a vehicle is declared out-of-service, it may not be moved under its own power to a place of repair. The following are three exceptions:

1. Vehicles transporting hazardous materials/dangerous goods that require placarding may be escorted to a repair facility or safe parking place.
2. When the imminently hazardous condition is automatically removed by the disconnection of the power unit from a towed unit, the power unit may be moved. When such an out-of-service power unit is operated, the examination report must carry the notation, "Power unit not to be operated in combination with another vehicle until repaired". In these instances a CVSA decal will not be issued.

There are three mechanical defect conditions, which meet this criterion:

- a. Defective coupling mechanism on the power unit.
 - b. Defective trailer supply valve, as long as the tractor protection valve is functional.
 - c. Defective emergency or service brake hoses, or tubing between tractor and trailer.
3. Vehicles transporting passengers that have been declared out-of-service for emergency exits that are missing, inoperative, or obstructed may be moved by driver to a location where the out-of-service condition can be repaired. At no time will the vehicle be moved in this condition with passengers aboard.

Location of CVSA Decals

The location for affixing a CVSA decal on a power unit shall be on the lower right corner of the exterior surface of the passenger's windshield.

The location for affixing a CVSA decal on trailing units (i.e., trailers, full trailers, semi-trailers, converter dollies, etc.) shall be on the lower right corner as near the front as possible.

The location for a CVSA decal on a cargo tank semi-trailer shall be at eye-level near the right front of the cargo tank and on the lower right corner of the exterior surface of the passenger's windshield of a straight truck.

The location for a CVSA decal on passenger vehicles shall be on the glass portion (window) of the passenger door as close to inspector's eye-level as possible.

Any expired CVSA decal shall be removed before a new CVSA decal is affixed.

Application of CVSA Decals

The quarter in which an inspection is performed is indicated by the color of the CVSA decal issued.

Inspection Period	Color Code
January, February, March	Green
April, May, June	Yellow
July, August, September	Orange
October, November, December	White

The year of issuance shall be indicated by using the last number of the calendar year (i.e., 2016 shall be indicated by the number “6”) and shall be printed at the top portion of the sticker, with the CVSA trademark printed directly below.

CVSA decals affixed on the first month of a new calendar quarter must have both upper corners removed. Those issued during the second month of the same quarter must have the upper right corner removed. No corners are removed from those CVSA decals issued during the last month of a calendar quarter.

CVSA decals, affixed, will remain valid for the month of issuance plus two months. For example, a CVSA decal issued on July 28 will expire September 30.

In general, vehicles displaying a valid CVSA decal are not subject to re-inspection. However, if an obvious defect is noticed on a vehicle with a current CVSA decal, nothing prevents a party from re-inspecting that vehicle.

Should re-inspection of a vehicle displaying a valid CVSA decal disclose vehicle maintenance inconsistent with the minimum inspection criteria, the CVSA decal must be removed. However, if the defects found are repaired at the scene, the CVSA decal does not have to be removed. In those instances where a complete re-inspection is performed and defects were absent or corrected at the scene, a new CVSA decal should be applied.

***Inspection Bulletins**

- *2015-09** — Motorcoach Emergency Roof Hatch Inspections
(Created 04-16-15)
- *2015-08** — Advancement in Motorcoach Air Brake Systems
(Created 04-16-15)
- *2015-07** — How to Properly Identify Shipper Violations
(Created 04-16-15)
- *2015-06** — Electric-Drive Commercial Vehicle Inspections
(Created 04-16-15)
- *2015-05** — Advanced 6 X 2 Tractor Inspections
(Created 04-16-15)
- *2015-04** — Enforcement of Medical Examiner's Certificate Integration with the Commercial Driver's License
(Created 04-16-15)
- *2015-03** — Safety Inspection Procedures for Vehicles Equipped with Air Suspension
(Created 01-21-15)
- *2015-02** — Safety Procedure for Lift Axle Inspection
(Created 01-21-15)
- 2014-02** — Identification of Long Stroke Brake Chambers
(Created 04-10-14)
- 2014-01** — Driveline/Driveshaft Inspections
(Created 04-01-14)
- 2013-02** — Antilock Brake Systems (ABS) Inspections
(Revised 09-19-13; Field References Updated 11-14-14)
- 2012-06** — Intermodal Equipment Provider Marking Options
(Revised 08-15-12)
- 2012-05** — Automatic On-Board Recording Devices (AOBRDs) Hand-Held
(Created 06-06-12)
- 2012-04** — Hydraulic Brake System Inspection Procedures
(Created 04-26-12)
- 2012-02** — Brake Pedal (Valve & Treadle Assembly) Inspections
(Created 02-01-12)
- 2011-03** — Securement of an Intermodal Container on an Intermodal Chassis
(Created 04-14-11)
- 2010-05** — MCI Buses with Detroit Diesel Engines
(Created 05-19-10)

- 2010-03** — Rack and Pinion Steering System Inspection
(Edited 10-27-14)
- 2010-02** — Inspection of Vehicles Equipped with 2007 & 2010 EPA Certified Engines
(Revised 05-19-10)
- 2010-01** — Tractor Protection Systems
(Revised 05-19-10)
- 2007-01** — Express Brake International, Inc. — Segmented Brake Linings
(Revised 09-15-08)
- 2006-01** — Camshaft Bushings
(Created 03-29-06)
- 2005-01** — Trailer Brake Controller [TBC] 2005 Ford SuperDuty Vehicles
(Created 01-04-05)

OPERATIONAL POLICY 15 INSPECTION / REGULATORY GUIDANCE

PURPOSE

Operational Policy 15 is intended to provide inspection and regulatory guidance pertaining to driver-vehicle inspections when using the recommended North American Standard Inspection Procedure. It also contains direction related to frequently asked questions related to the *North American Standard Out-of-Service Criteria (OOSC)*.

OBJECTIVES

1. Clarify frequently asked questions related to the OOSC.
2. Provide guidance for regulations on an interim basis until such time as regulations can be amended.
3. Maintain an up-to-date policy to ensure guidance's and interpretations outlined in the policy are current.
4. OOS clarifications are outlined as they are referenced in the OOSC.

NOTE: *Regulatory Guidance's should be used for all U.S. Federal Motor Carrier Safety Regulations and in Canada and Mexico where there is not specific regulation to supersede the guidance.*

Documenting violations before the limits specified in the guidance below adversely impact a carrier's safety rating unnecessarily and require a carrier to spend time and money to repair a condition that presently does not affect the safe operation of the vehicle. Maintenance issues cannot be recorded as violations.

The following are current interpretations and guidance:

1. BRAKE SYSTEMS

OOS Frequently Asked Questions

- a.(1) When an air leak is found at a fitting, when should it be placed out-of-service?

ANSWER: A proper connection is a glad hand connection or where two metal fittings join together. An air hose with a leak at the hose side of a fitting is not considered a proper connection.

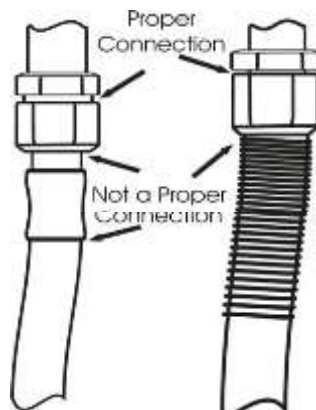

Regulatory Guidance

- b.(1) When should cracks in brake linings (including rust jacking) not be recorded as a violation?

ANSWER: A violation should not be recorded until a crack exceeds the limit specified in the Commercial Vehicle Safety Alliance (CVSA) OOSC, i.e., until a crack exceeds 1/16inch (1.6 mm) wide or 1-1/2 inch (38.1 mm) in length.

- b.(2) When should air hoses not be documented as a violation for chafing?

ANSWER: A violation should not be recorded until a reduction of the hose diameter is observed. It is not a violation if the hoses/lines rest on, or lightly rub on vehicle components. A hose that is found to have a reduction in diameter but is no longer chafing does not constitute a violation unless damage extending to or through the outer reinforcement ply is observable; when damage extends to or through the outer reinforcement ply a violation will be recorded (thermoplastic nylon tubing that is discoloured or faded but not damaged, is not a violation).

NOTE: If inspectors observe air hoses/lines that appear to be resting on or lightly rubbing on vehicle components, but no observable reduction is present, inspectors should educate the driver that this is a condition that, while not in violation, is a condition that could lead to a violation/OOS condition in the future and make comments in the notes only, if so inclined.

- b.(3) When should an air leak in the brake system be documented as a violation?

ANSWER: When a vehicle has an air leak at a proper connection or at an undetermined location, and the vehicle passes the CVSA OOSC air loss rate test, inspectors will record a violation for an air leak on the inspection report.

NOTE: In Section 393.45(d) it indicates that the leak has to affect the brake performance under 393.52. Enforcement cannot determine to what extent a leak has to be to affect the brake performance, therefore, any leak in the brake system will be documented as a violation.

2. CARGO SECUREMENT

OOS Frequently Asked Questions

- a.(1) Shall a tiedown used to secure auxiliary equipment on a heavy vehicle be used in the calculation of the aggregate working load limit?

ANSWER: Yes

Regulatory Guidance

- b.(1) Can a bungee cord or tarp strap be used as a primary means of securing an article of cargo and does it need to be rated and marked with a working load limit (WLL)?

ANSWER: Bungee cords and tarp straps are not suitable for use as tiedowns, and are equally unsuited to having an assigned WLL. There is no intention to prohibit the use of these devices as supplementary restraint for light weight cargo and equipment.

b.(2) When should a violation be recorded for a damaged tiedown?

ANSWER: All tiedowns being used to secure cargo (whether they are required or not) that are damaged to the extent outlined in the CVSA OOSC Cargo Securement Tiedown Defect Table will be recorded as a violation. All other tiedowns with damage not yet to that extent will not be recorded.

b.(3) When transporting “metal coils with eyes crosswise”, other than what is currently outlined in regulation, is there any other means of acceptable securement?

ANSWER: Yes, there is a temporary exemption from the regulations if coils are loaded to contact each other in the longitudinal direction, and relative motion between coils, and between coils and the vehicle, is prevented in accordance with the requirements outlined in the ‘Metal Coil Exemption’.

b.(4) Other than general provisions, is there a method to secure baled hay and straw that is considered to meet the requirements of 49 CFR 393.102(c) as an “an equivalent means of securement”?

ANSWER: Yes, providing it meets the requirements outlined in the Technical Review available in the ‘Technical Review of Industry Cargo Securement Practices for Square Bales of Hay and Straw Memo’.

b.(5) Is stretch film and/or shrink-wrap an acceptable means of unitizing cargo?

ANSWER: Yes, as long as all of the individual articles in the unit of cargo remain secured inside the surface of the material.

b.(6) Is a baled, logged or rolled car considered a “crushed” car for cargo securement specific commodity requirements relative to FMCSR 393.132 & NSC 10, Division 7, Section 90-92.

ANSWER: A “crushed car” means a vehicle that has been subjected to mechanical compression that reduces the vehicle’s height as part of a recycling process, without significantly reducing the vehicle’s length or width. A cube of miscellaneous crushed metal must be secured by the general cargo requirements.

b.(7) How must a friction mat be marked to show its coefficient of friction (CoF) value?

ANSWER: The CoF, in a numeric value, must be visible. (e.g.: 0.5g or 0.8g)

3. COUPLING DEVICES

Regulatory Guidance

b.(1) When should movement in the fifth wheel not be documented as a violation?

ANSWER: A violation should not be noted until one of the following conditions is met:

- Horizontal movement between the pivot bracket pin and bracket exceeds the CVSA OOSC limit, 3/8 inch (9.5 mm) or;
- Movement between slider bracket and slider base exceeds the CVSA OOSC limit, 3/8 inch (9.5 mm) or;
- Horizontal movement between the upper and lower fifth wheel halves exceeds the CVSA OOSC limit, 1/2 inch (12.5 mm)

b.(2) When should a violation of the mounting and integrity of a pintle hook/drawbar not be documented on a semi-trailer?

ANSWER: A violation of the coupling device on a semi-trailer should not be documented until the CVSA OOSC is met and in the U.S., the violation should be recorded under 396.3(a)(1). This is necessary because 393.70(c)&(d) only apply to full trailers.

8. LIGHTING SYSTEMS

Regulatory Guidance

b.(1) When shouldn't a violation be documented for inoperative clearance lights on trailers that require them?

ANSWER: A violation should not be noted unless the vehicle does NOT have clearance lights on either the upper location or the lower location. In some instances trailer manufacturers may be installing the clearance lamps at a location lower than the upper rear corners of the trailer. This is allowed when the practicability of mounting the rear clearance lamps in the header is problematic.

b.(2) What lighting is required on a converter dolly?

ANSWER: Despite the wording in Footnote 5 of Section 393.11 of the FMCSRs, after an exhaustive review of rulemaking documents, the following will dictate when a violation should be recorded:

- *"Laden" converter dolly* – no lights required;
- *Converter dolly towed singly by another vehicle and not part of a full trailer* one stop lamp, one tail lamp, two reflectors, (one on each line of the vertical centerline, as far apart as practicable) on the rear (this assumes that the turn signals of the towing unit are not obscured);
- *Converter dolly towed singly by another vehicle and not part of a full trailer, AND the converter dolly obscures the turn signals at the rear of the towing vehicle* - one stop lamp, one tail lamp, two reflectors, (one on each line of the

vertical centerline, as far apart as practicable) on the rear, and rear turn signals and vehicular hazard warning signal flashing lamps.

- b.(3) Retro-reflective sheeting is required to be applied to both sides of the trailer at a height of at least 380 mm (15 inches) and not more than 1525 mm (60 inches) above the road surface. In some cases, when this height is complied with on tank trailers, the sheeting will be canted downwards. Therefore, in some cases, the sheeting is applied higher than what is outlined in the regulations but is located “as close as practicable” to the required height and still allows for the tape to be mounted on a horizontal plane or as close to it as the shape of the trailer allows. In these cases, should a violation be documented?

ANSWER: No, if a cargo tank does not have a frame or other suitable surface below the 1525 mm (60 inches) height to apply the sheeting in order for it to be on a horizontal plane, the sheeting may be located at a higher location, as close to the required height as practicable and no violation should be documented.

9. STEERING MECHANISMS

Regulatory Guidance

- b.(1) When should vertical or horizontal movement in a ball and socket joint not be documented as a violation?

ANSWER: A violation should not be noted until motion, other than rotational, between any linkage member and its attachment point exceeds the limit prescribed in the CVSA OOSC, i.e., 1/8 inch (3.2mm), measured with hand pressure only.

NOTE: FMCSA is aware of the discrepancy between the measurement in Appendix G and the CVSA OOSC. Using the CVSA OOSC as a guideline allows for some play in the ball and socket joint, but more importantly, provides inspectors with an objective measurement criterion that will ensure uniformity when writing the violation.

*10. SUSPENSIONS

*OOS Frequently Asked Questions

- a.(1) In a Peterbilt air suspension assembly, is a loose or missing spring eye u-bolt an out-of-service condition (see diagram below)?

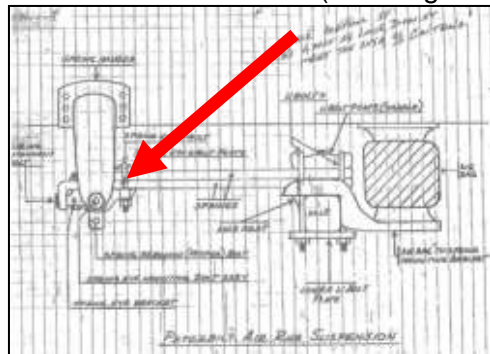

ANSWER: No, not unless it has somehow resulted in axle displacement.

a.(2) Is a loose or missing rebound bolt a violation or OOS?



ANSWER: A rebound bolt in a spring hanger or equalizer that is loose is not considered a violation. A missing or broken rebound bolt is considered a violation but not OOS.

a.(3) If the cross tube brace is cracked, loose, corroded or broken, is it a violation or an OOS condition?

ANSWER: No, the “cross tube brace” is used to position the suspension for shipment and installation and has no bearing on the alignment or the function of the suspension.



*a.(4) What is the difference between a primary and aftermarket/secondary air bag suspension?

ANSWER: The primary air bag suspension system is maintained in accordance with original manufacturer specifications whereas a secondary air bag suspension system is in addition to the original manufacturer spring or coil suspension.



Original Manufacturer Equipment
(Leaf/Air Primary Suspension)



Aftermarket/Secondary Air Suspension
(Air Bag Supplements the Primary Leaf Spring Assembly)

NOTE: Deflated aftermarket/secondary air bag suspension in addition to a primary leaf/coil spring suspension does not result in a violation.

11. TIRES

OOS Guidance

- a.(1) What is a major tread groove on a tire for the purposes of measuring tread depth?

ANSWER: A major tread groove is the space between two adjacent tread ribs or lugs on a tire that contains a tread wear indicator or wear bar. (In most cases, the locations of tread wear indicators are designated on the upper sidewall/shoulder of the tire on original tread tires.)

Regulatory Guidance

- b.(1) If a tire has a max inflation pressure of 110 psi, but measures 80 psi, should a violation be written, if so what section?

ANSWER: No, a violation should not be written. In order to issue a violation for having low inflation pressure, the inspector would have to have a chart which identifies the load carrying capacity for the tire at different inflation pressures as well as for the particular load that is being carried. There are too many different tire sizes to put this level of information into the regulation.

An underinflated tire is not a violation until it meets the OOSC and 393.75(a)(3) is the proper section to be used. 393.75(h) should not be written for an underinflated tire. A violation of 393.75(f) violation should only be written when the opportunity to weigh a vehicle is present, and the weight on a tire exceeds the tire load carrying capacity (as printed on the sidewall of the tire).

13. WHEELS, RIMS AND HUBS

OOS Frequently Asked Questions

- a.(1) Is it an OOS condition when a vehicle has had a tire or rim problem and a driver or owner has either singled out the axle or has removed the wheels and chained up the axle?

If the vehicle arrives at an inspection site in this condition, this is not a violation unto itself, but other violations may have resulted from this action (e.g., exceeds tire weight rating).

However, if a vehicle is inspected, the driver should not be permitted to single-out a tire or chain up an axle as a “quick fix” for an out-of-service defect. This does not comply with CVSA Operational Policy 5 which states:

“...REQUIRED REPAIRS FOR OUT-OF-SERVICE NOTICES

The following shall be the policy regarding required repairs for out-of-service notices:

No motor carrier shall require nor shall any person operate, or any inspector release any commercial motor vehicle declared “out-of-service” until all repairs required by the “out-of-service notice” have been satisfactorily completed to where a violation no longer exists. ...”

XX. MISCELLANEOUS

Regulatory Guidance

b.(1) When should a violation not be noted for external visors that have been added to a vehicle that obstruct the view of the driver?

ANSWER: Section 393.60(e)(1) of the FMCRs only applies to items that are mounted on the windshield, not in front of the windshield. Temporary exemptions have been granted to numerous carriers to allow video event recorder and some lane-departure warning system sensors to be mounted on the interior of the windshield, within the top 2 inches of the windshield wiper sweep for a period of two years. During the time period that these exemptions are in force, no State agency shall enforce any law or regulation that conflicts with or is inconsistent with the exemption. There is no current guidance as to how much of the windshield can be covered by external visors, so in extreme cases where a significant portion of the windshield is obscured by external visors mounted in front of the windshield, a violation can be documented under 396.3(a)(1) or 393.3.